

DOCUMENT FEEDER

1. OVERALL MACHINE INFORMATION

1.1 SPECIFICATIONS

Original Size and Weight:	<ul style="list-style-type: none"> - Thin original mode - <ul style="list-style-type: none"> Maximum 11" x 17"/A3 Minimum 5½" x 8½"/A5 sideways Weight 11 to 34 lb/41 to 128 g/m² - Thick original mode - <ul style="list-style-type: none"> Maximum 11" x 17"/A3 Minimum 5½" x 8½"/A5 sideways Weight 14 to 34 lb/52 to 128 g/m² - Auto reverse mode - <ul style="list-style-type: none"> Maximum 11" x 17"/A3 Minimum 8½" x 11"/A5 sideways Weight 17 to 28 lb/64 to 104 g/m²
Original Feed:	<p>Automatic feed — ADF mode Manual feed one by one — SADF mode</p>
Original Table Capacity:	<p>35 sheets (17 lb/64 g/m²) Maximum thickness of stacked originals: 3.4 mm</p>
Original Set:	Face up, front side. First sheet on top.
Original Transport:	One flat belt
Copy Speed:	<ul style="list-style-type: none"> - One sided mode - <ul style="list-style-type: none"> 20 copies/minute for 8½" x 11"/A4 sideways (1 to 1 copy) - Auto reverse mode - <ul style="list-style-type: none"> 2 copies/minute for all sizes
Power Consumption:	24 W
Dimensions (W x D x H):	27.2" x 20.4" x 4.2"/690 x 519 x 107 mm
Weight:	Approximately 21.4 lb/9.7 kg
Nonrecommended Paper:	<p>The following types of paper cannot be used with the DF.</p> <ol style="list-style-type: none"> 1) Dog-eared, torn, or creased paper 2) Paper with holes larger than 6 mm in diameter 3) Damp paper 4) Coated paper (carbon paper, thermal paper, etc.)

- 5) Curled paper
- 6) Paper with clips or staples
- 7) Originals that are glued or taped together
- 8) Bound originals
- 9) Translucent paper (can be used in SADF mode)

1.2 MECHANICAL COMPONENT LAYOUT

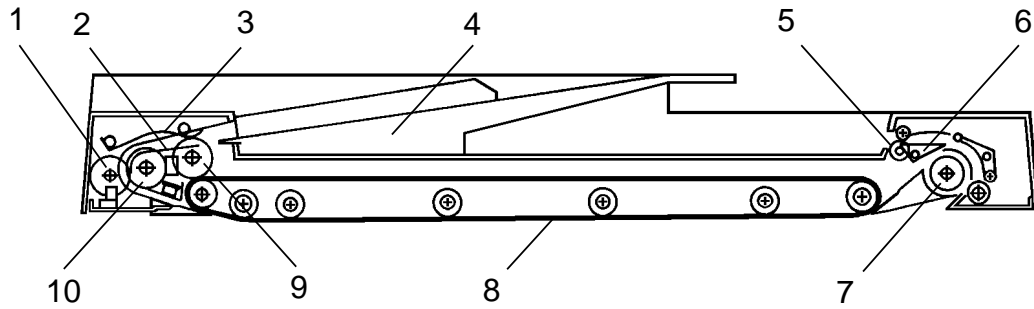

- | | |
|-------------------------|--------------------|
| 1. Pulse Generator Disk | 6. Inverter Pawl |
| 2. Friction Belt | 7. Inverter Roller |
| 3. Pick-up Lever | 8. Transport Belt |
| 4. Original Table | 9. Pick-up Roller |
| 5. Exit Roller | 10. Feed Roller |

1.3 ELECTRICAL COMPONENT DESCRIPTIONS

SYMBOL	NAME	FUNCTION	LOCATION
Motors			
M1	Belt Drive Motor	DC servomotor that drives to the transport belt and feed-in system (pick-up roller, feed roller, pull-out roller and relay roller).	6
M2	Feed-out Motor	DC servomotor that drives the feed-out unit of the DF.	11
Solenoids			
SOL1	Pick-up Solenoid	Energizes to press the pick-up lever against the stack of originals in preparation for original feed-in.	5
SOL2	Feed-in Solenoid	Turns on to engage the feed-in clutch so rotation is transmitted to the feed roller, pull-out rollers, and relay rollers.	14
SOL3	Inverter Solenoid	Energizes to invert the original when copying two sided originals.	10
SOL4	Stopper Solenoid	Energizes to down the original stopper of the copier.	15
Switches			
SW1	Lift Switch	Informs the CPU when the DF is lifted and also serves as the jam reset switch for the DF.	8
SW2	Original Select Switch	Selects thick original mode or thin original mode.	13
Sensors			
S1	Original Set Sensor	Informs the copier CPU that originals have been placed and causes the Insert Original indicator to go out.	1
S2	Registration Sensor	Sets original stop timing and measures original length.	2
S3	Original Width Sensor	Determines the width of the originals.	4
S4	Pulse Generator Sensor	Generates pulses used to measure the original length.	3
S5	Feed-out Sensor	Checks for original misfeeds and sets original stop timing when in auto reverse mode.	12
S6	ADF Position Sensor	Informs the CPU when DF is being closed so that APS sensor can begin checking the original size.	16
Printed Circuit Boards			
PCB1	DF Main Board	Controls all DF functions.	9

PCB2	Indicator Panel Board	Contains operator indicators.	7
------	-----------------------	-------------------------------	---

1.4 OVERALL MACHINE CONTROL

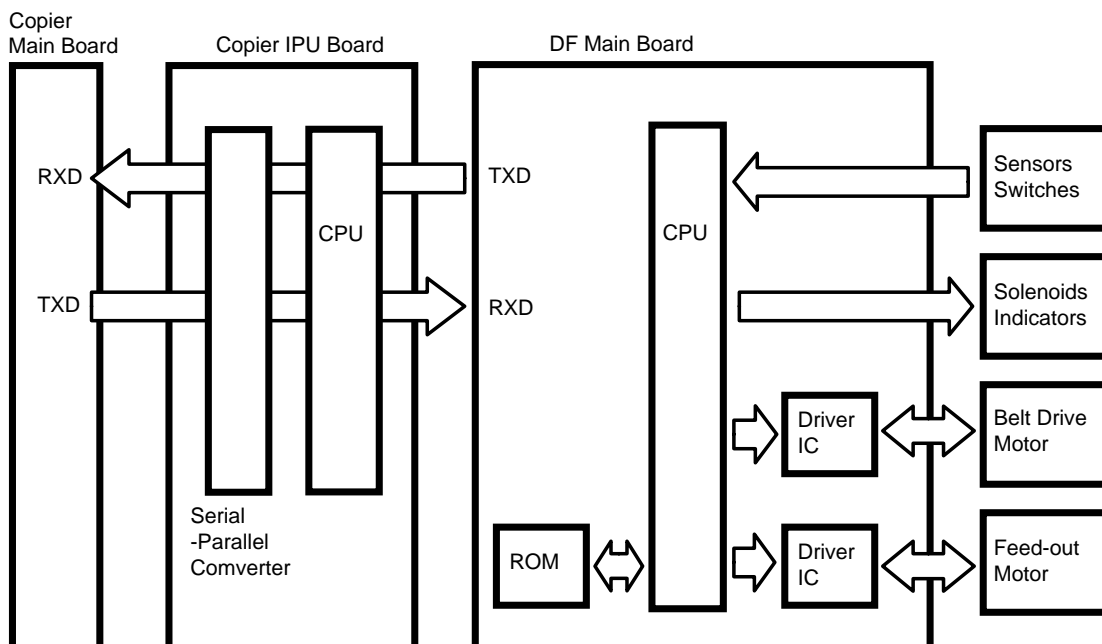

The DF CPU monitors the input signals from the sensors and switches, and energizes the solenoids and the indicator LEDs directly. The belt drive motor and the feed-out motor are controlled by the DF CPU through their respective driver ICs.

Also, the DF CPU communicates with the copier using a serial interface. The exchanged signals are shown in the tables on the next page.

1. DF ⇒ Copier

No.	Signal Name	Definition
1	Original Set	Originals are set on the original table.
2	Copy Start	Allows the copier to start copy sequence.
3	Lift Up	The DF is lifted.
4	DF Misfeed	Misfeed occurs in the DF.

2. Copier ⇒ DF

No.	Signal Name	Definition
1	Feed-in	Requests the DF to feed-in the original.
2	Feed-out	Requests the DF to feed-out the original.
3	Invert Original	Requests the DF to invert the original.
4	Auto Feed	Shifts the DF to the auto feed mode.
5	Original Stay	Attempt to use DF but the original from the previous copy run remains on the exposure glass.

1.5 BASIC OPERATION

1. One-sided Original Feed

When an original is inserted into the DF, the Insert Original indicator light goes out and the DF informs the copier CPU that originals have been set.

When the Start key is pressed, the copier CPU sends the feed-in signal to the DF. On receipt of this signal, the DF energizes the pick-up solenoid, the feed-in solenoid, and the belt drive motor in order to feed-in the bottom sheet of the original stack onto the exposure glass. The pick-up solenoid and the feed-in solenoid remain energized until the original's leading edge reaches the DF registration sensor. The belt drive motor turns off 2,088 encoder pulses after the original's leading edge passes the DF registration sensor.

While feeding the original, the DF registration sensor and the paper width sensor check the original size.

Shortly before the belt drive motor turns off, the DF CPU sends the copy start signal to the copier. On receipt of the signal, the copier CPU starts the copy cycle.

When the scanner reaches to the return position, the copier CPU sends the feed-out and the feed-in signals to the DF CPU in order to exchange the original with the next original.

When the scanner comes to the return position after scanning the last original, the copier CPU only sends the feed-out signal in order to feed-out the last original.

2. Two-sided Original Feed

Unlike one-sided original feed, the back side of the original must be copied first to keep the originals and copies in the correct order.

During original feed-in, the sequence is the same as for one-sided feed; however, the DF CPU also energizes the feed-out motor and the inverter solenoid a short time after the original's leading edge has passed the DF registration sensor. The belt drive motor continues to feed the original until 140 milliseconds after the original leading's edge passes the feed-out sensor. At this point the inverter mechanism inverts the original, in preparation for copying the back side. Then the belt drive motor reverses and the original is fed towards the original stopper and is stopped at the correct position on the exposure glass. The DF CPU sends the copy start signal a short time after the original's trailing edge has passed the feed-out sensor.

When the scanner reaches to the return position, the copier CPU sends the invert original signal to the DF CPU in order to make a copy of the front side. The original is inverted in the same way as for back side copying.

3. Semi-automatic Document Feed

If a single original is inserted into the original table and copied, the DF shifts to the semi-automatic feed mode and lights the Auto Feed indicator. The Auto Feed indicator remains on for five seconds after the copier main motor stops. If another original is inserted within that five-second period, it is automatically fed and copied.

2. DETAILED SECTION DESCRIPTION

2.1 ORIGINAL FEED

2.1.1 Original Pick-up

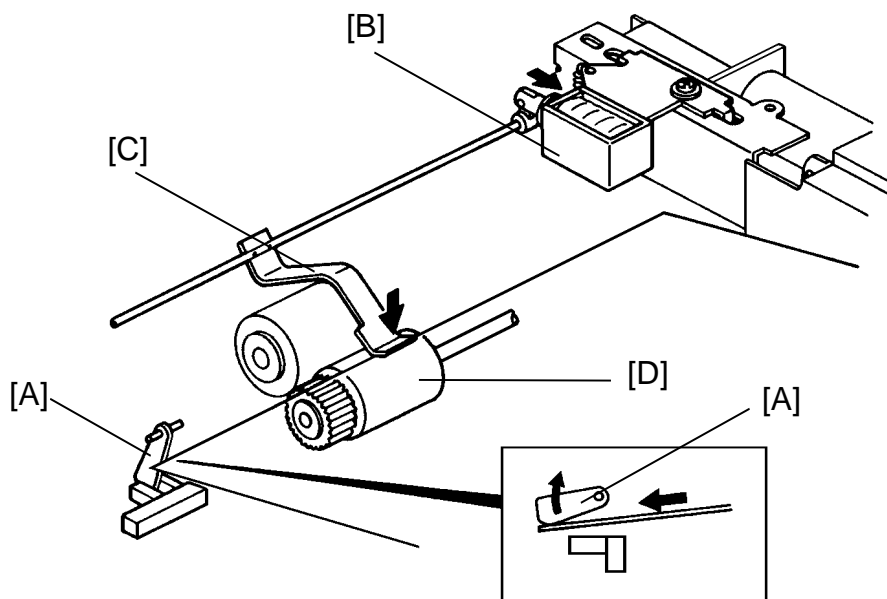

After setting the originals on the original table, the originals contact the feeler [A] of the original set sensor and cause the feeler to move out of the sensor. The DF then sends the original set signal to the copier CPU to inform it that the DF will be used. When the Start key is pressed, the pick-up solenoid [B] is energized. The original stack is then pressed between the pick-up lever [C] and pick-up roller [D]. The rotation of the pick-up roller advances the bottom original.

2.1.2 Original Separation

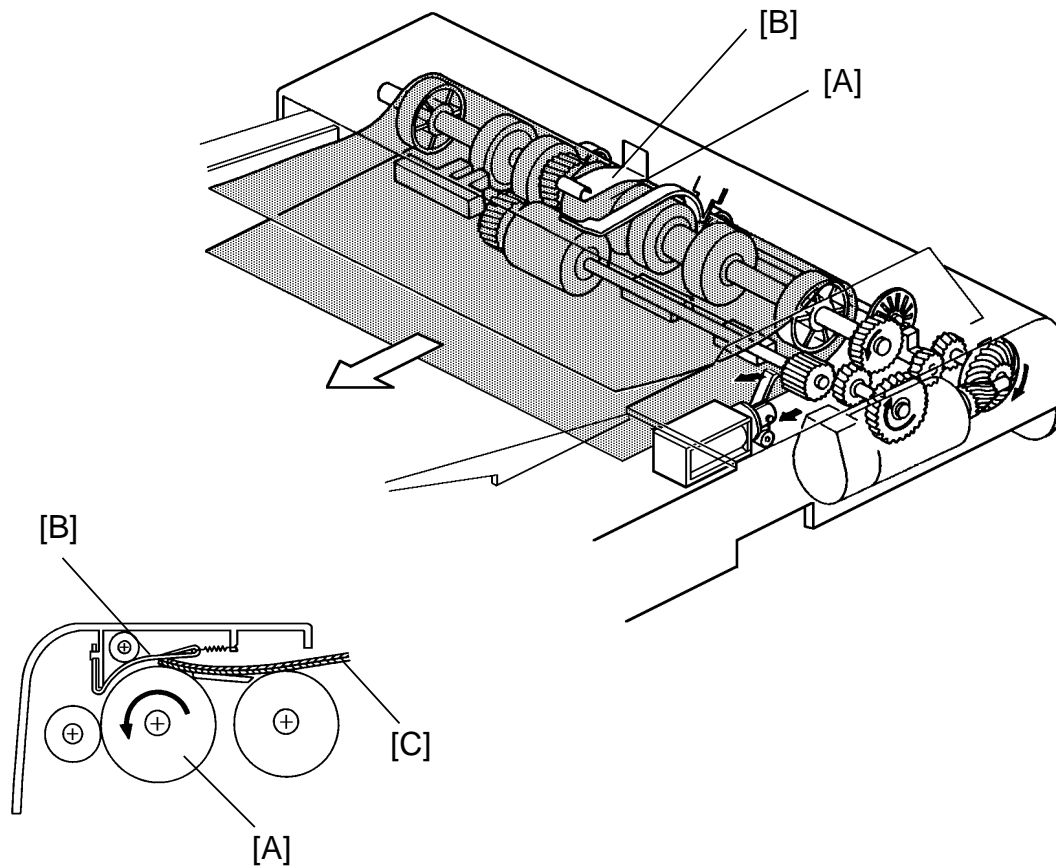

The feed roller [A] and the friction belt [B] are used to feed-in and separate the originals [C]. Only the bottom original is fed because the friction belt prevents any other originals from feeding.

Original feed starts when the feed roller starts turning and advances the bottom original of the stack. The feed roller moves the original past the friction belt because the driving force of the feed roller is greater than the resistance of the friction belt. The friction belt prevents multiple feeds because the resistance of the friction belt is greater than the friction between original sheets.

2.1.3 Original Feed-in Mechanism

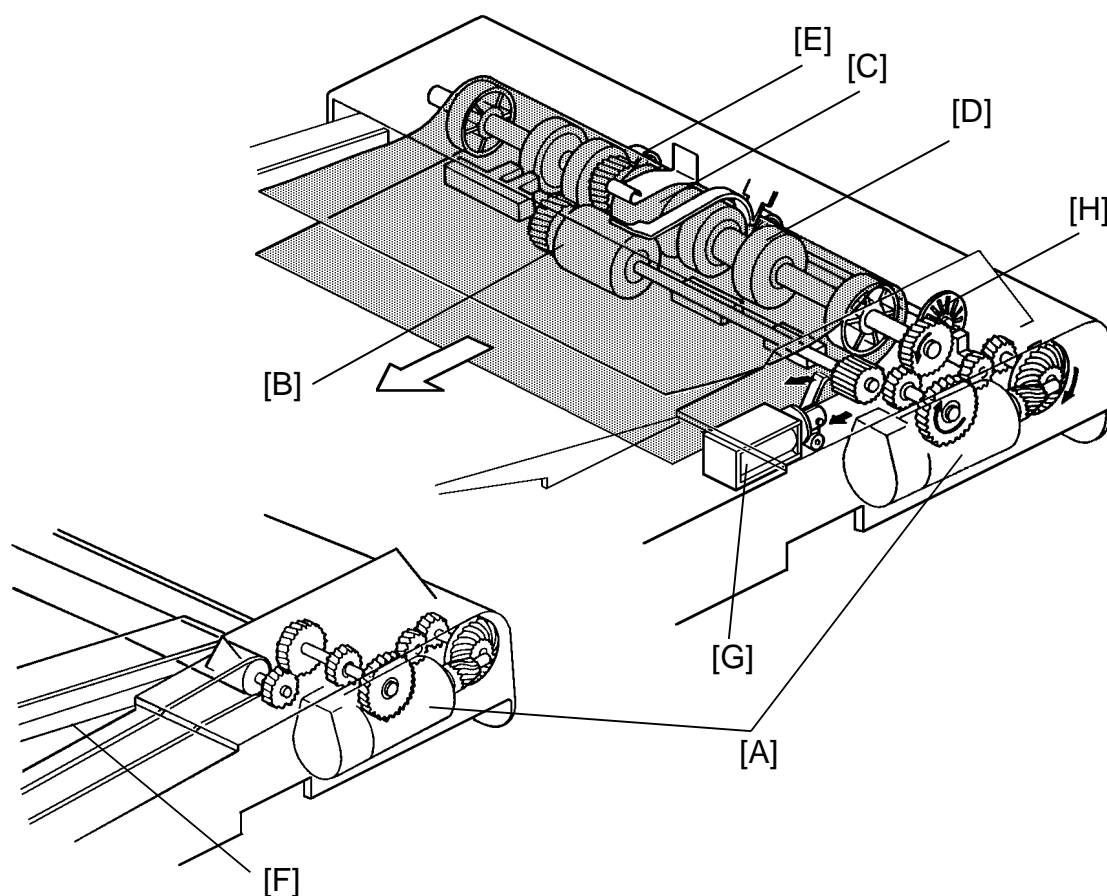

The belt drive motor [A] drives the pick-up roller [B], the feed roller [C], the pull out roller [D], the relay roller [E], and transport belt [F] via a feed clutch and a gear train.

The pick-up solenoid and feed-in [G] solenoids are energized 100 milliseconds after the Start key is pressed. Then 200 milliseconds after the solenoids are energized, the belt drive motor starts turning. The pulse generator disc [H] always turns when the belt drive motor is on.

2,088 encoder pulses of the belt drive motor after the original's leading edge passes the registration sensor, the relay rollers and the transport belt stop turning.

2.1.4 Original Size Detection

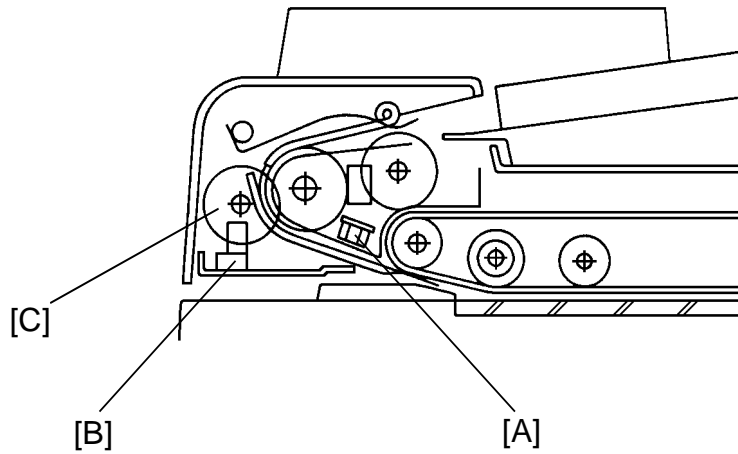

The DF determines original size (both width and length) through the use of the original width sensor [A, rear of DF], registration sensor [A, center of DF], and pulse generator sensor [B]. The original's length is calculated by counting the number of pulses from the pulse generator [C] while the registration sensor is on.

Original size detection is necessary for the feed-in/feed-out timing of the DF.

2.1.5 Original Stopping Mechanism

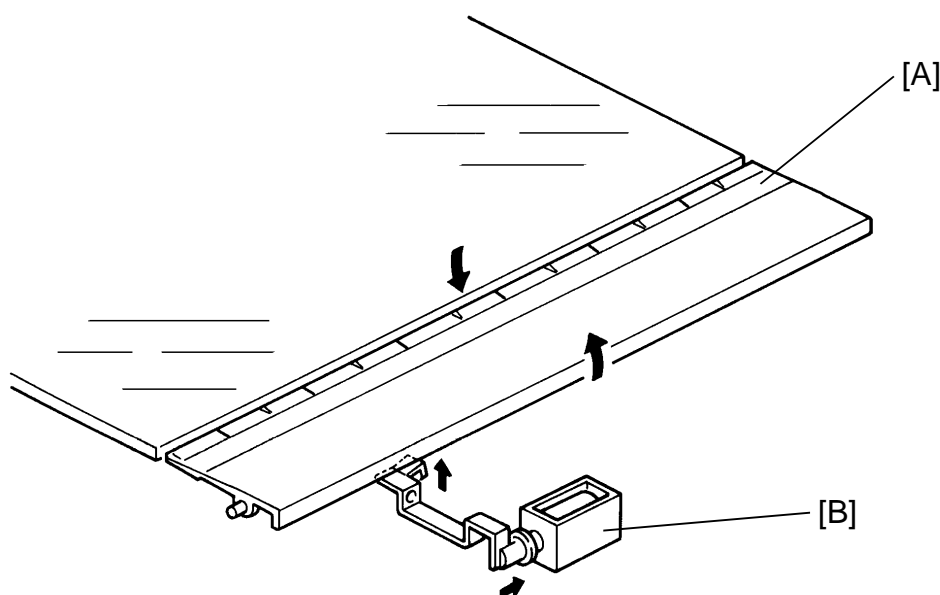

- Original Stopper -

The original stopper [A] is used to align the edge of the original with the right original scale when the thick original mode is selected.

When the thin original mode is selected, the original stopper solenoid [B] is energized 200 milliseconds after the original's leading edge passes the registration sensor and thus the original stopper is held down until the original is stopped on the exposure glass.

This is to prevent damaging the original's leading edge against the original stopper.

- NOTE:**
- a) Before the original stopper moves down to feed out the original from the exposure glass, the belt drive motor reverses, pauses slightly, and then turns forward. This is to prevent the original's leading edge from being caught between the original stopper and the exposure glass.
 - b) The speed of the belt drive motor drops to 1,300 rpm from 2,500 rpm 1,812 pulses after the original's leading edge passes the registration sensor. This makes it easier for the mechanism to stop the original at the correct position on the exposure glass.

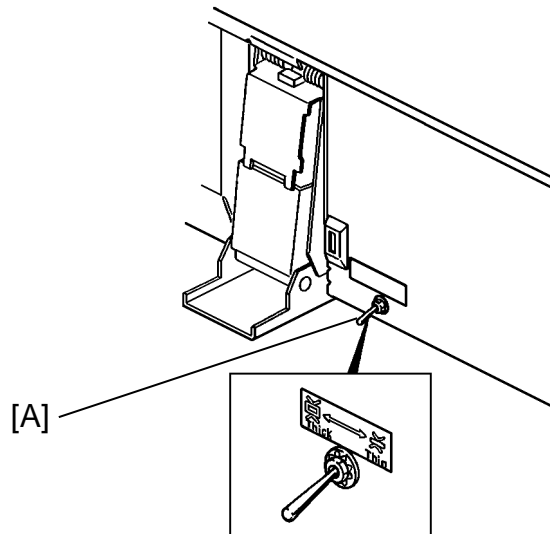

- Original Select Switch -

This document feeder has two different ways of stopping original at the correct position on the exposure glass. They are called the "thin original mode" and the "thick original mode". The mode used is determined by the original select switch [A].

1. Thin Original Mode

The original is stopped at the correct position on the exposure glass based on encoder pulse count. The belt drive motor stops 2,088 encoder pulses after the original's reading edge passes the registration sensor at the one-sided original mode. When the original is inverted in the inverter section, the belt drive motor stops 422 encoder pulses after the original's trailing edge passes the feed-out sensor. (Exact timing depends on registration adjustment.) Thin original mode is selected at the factory.

2. Thick Original Mode

When the thick original mode is selected, the original is aligned against the original stopper. The belt drive motor stays on 21 encoder pulses longer than when in the thin original mode. When the original is inverted, the belt drive motor continues to reverse for 52 encoder pulses longer than when in the thin original mode, and then turns forward for 188 encoder pulses. This forces the original against the original stopper and thus aligns the edge of the original with the original stopper.

NOTE: The thick original mode should be used when the customer requires more correct leading edge registration adjustment and/or complains of skewed copies. The thin original mode is to prevent the thin original's from being bent since they do not have great stiffness.

2.1.6 Original Inversion Mechanism

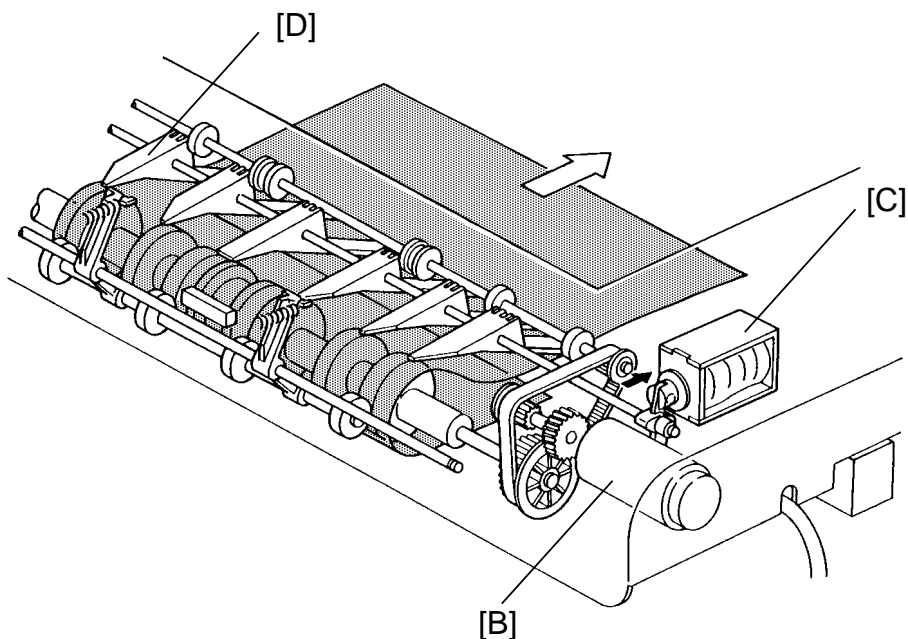

The two sided originals are inverted in the feed-out unit.

- 1) When the Start key is pressed, the two sided original is fed into the feed-in unit, passing over the DF registration sensor [A]. The feed-out motor [B] and the inverter solenoid [C] turn on 200 milliseconds after the original's leading edge passes the registration sensor. When the inverter solenoid turns on, the inverter pawls [D] rotate counterclockwise.

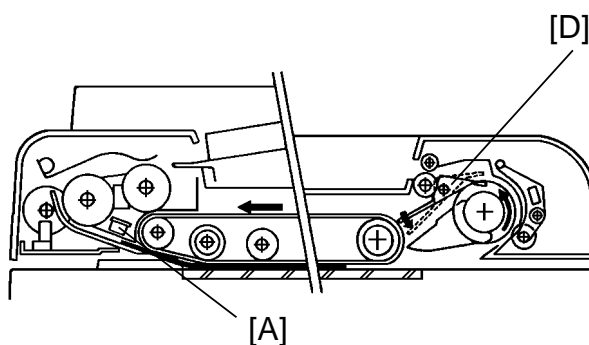

Document Feeder

- 2) The original is passes over the exposure glass [A] and feeds into the feed-out unit.

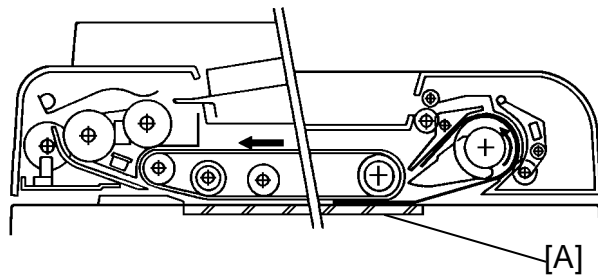

- 3) The original is directed onto the exposure glass again by the inverter pawls. The belt drive motor now reverses 140 milliseconds after the feed out sensor [B] turns on. The transport belt then moves the original toward the original stopper.

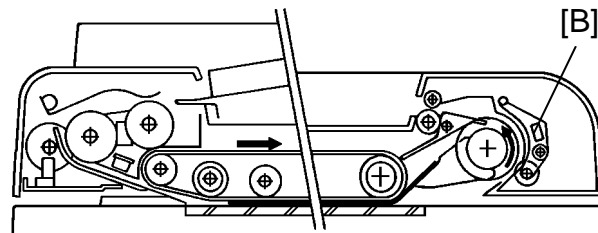

When the original leading edge reaches the original stopper, the belt drive motor stops. At the same time, the feed-out motor and the inverter solenoid turn off.

- 4) After the reverse side of the original is exposed, the belt drive motor, the feed-out motor, and the inverter solenoid turn on, and the original is fed into the inverter section. (This is the same as step 2 above.)

- 5) The original is fed onto the exposure glass again as in step 3 above. The front side of the original is then copied.

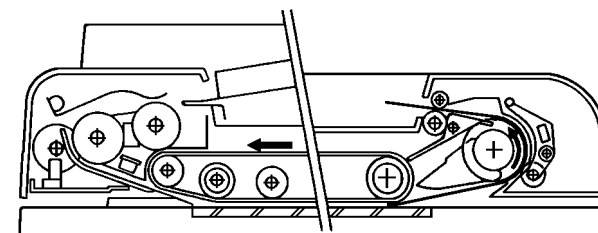

- 6) After the front side of the original has been exposed, the original is fed out from the DF.

2.1.7 Original Feed-out Mechanism

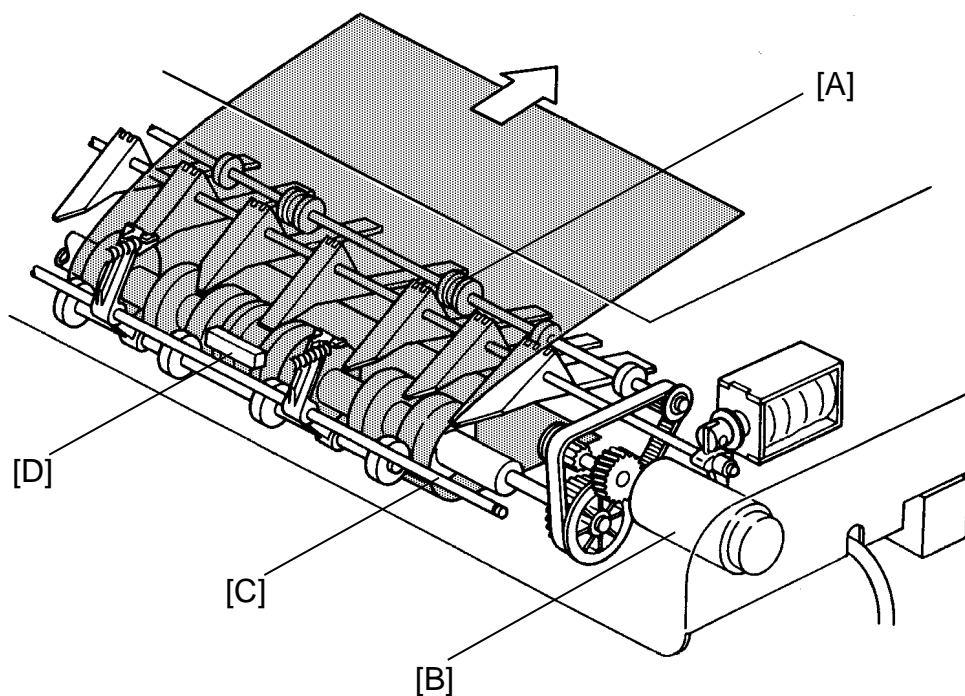

The exit rollers [A] are driven by inverter motor [B]. When the document feeder receives the feed out signal from the copier, the transport belt and the exit rollers start turning simultaneously. The transport belt carries the original to the inverter rollers [C] and the exit rollers take over the original feed-out. When the original's trailing edge passes the feed-out sensor [D], the feed-out motor drops to half of its normal speed for 220 milliseconds and then stops. The lower speed prevents uneven stacking of originals. For double letter size originals, the feed-out motor speed does not change due to the length of the originals.

2.1.8 Belt Drive Motor Circuit

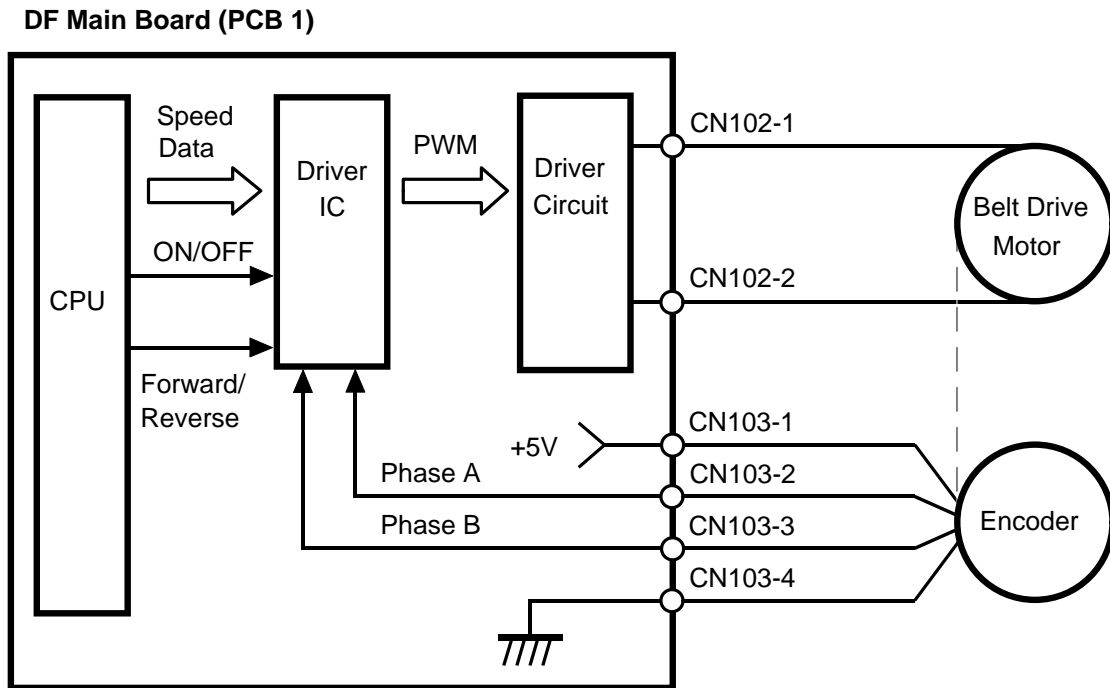

A dc servomotor is used as the belt drive motor. The driver IC controls the speed of the belt drive motor. The CPU sends the speed data (programmed) to the driver IC. The driver IC sends the pulse-width-modulation (PWM) signal to the driver circuit, which sends the motor drive pulses.

An encoder in the servomotor has two magnetic sensors that generate two pulse signals (phase A and B). The driver IC monitors the belt speed and direction by these pulse signals and uses this data to regulate the motor's speed.

2.1.9 Feed-out Motor Circuit

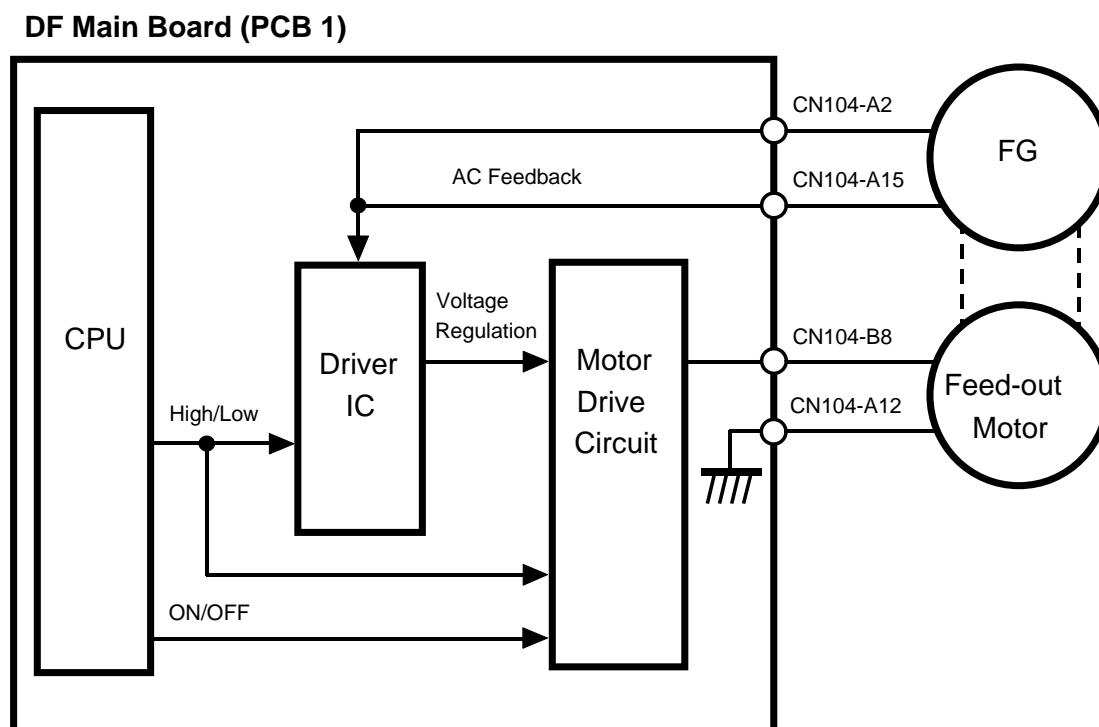

The DF CPU sends the speed data (high or low) to the driver IC and the motor drive circuit. The motor drive circuit creates the PWM signal and sends the motor drive pulses to the feed-out motor.

The frequency generator of the feed-out motor makes a very low voltage ac current which is fed back to the driver IC. The driver IC monitors the frequency of this ac current and based on the frequency it regulates the motor speed.

2.1.10 Input and Output Circuits

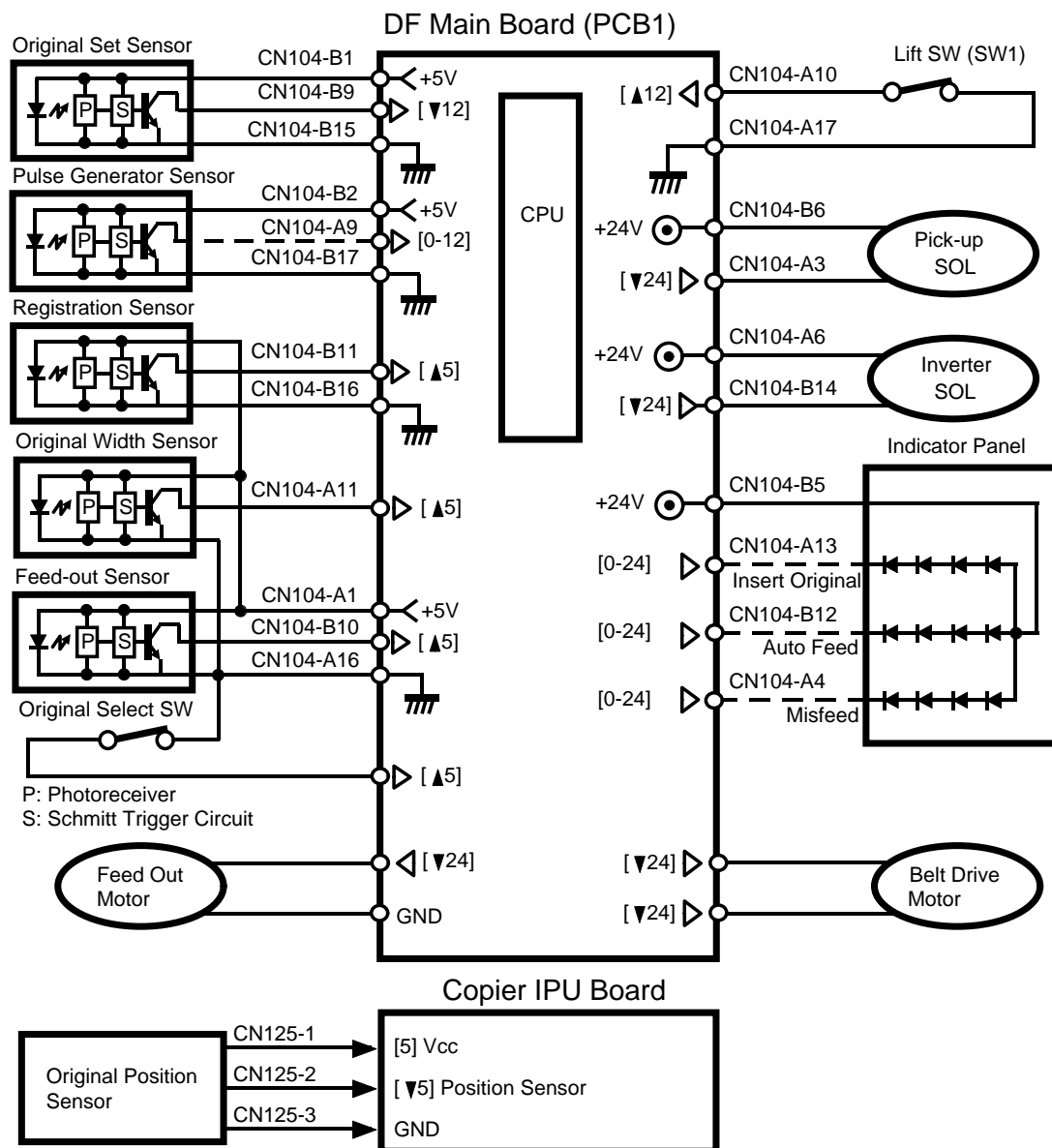

The above devices are directly controlled and monitored by the CPU. The solenoids, motors and indicator panel are energized with +24 volts. The sensors and switches are energized with +12 volts or +5 volts.

To energize a solenoid or indicator, the CPU drops the connected trigger line from +24 volts to LOW. The CPU monitors the input lines of the sensors and switch to determine when they are activated.

2.2 LIFT MECHANISM

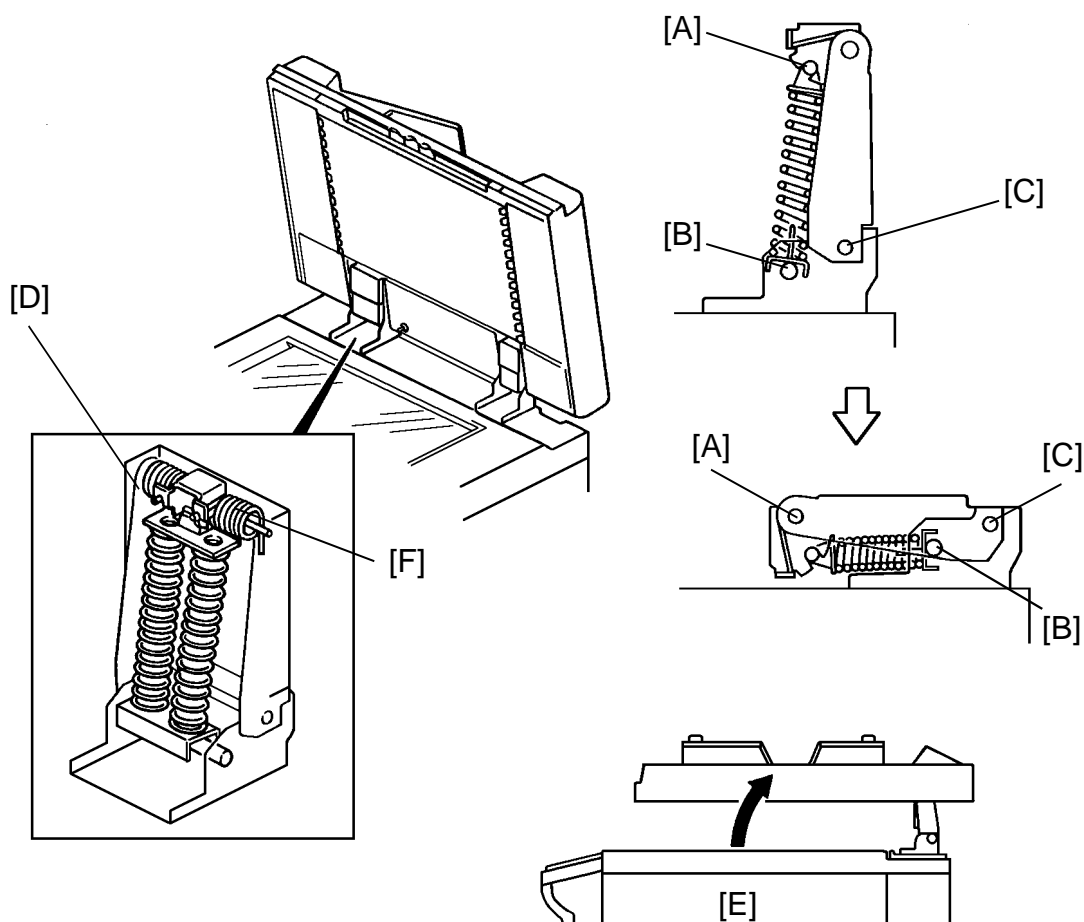

When the document feeder is opened, the lift springs [D] provide enough force to ensure that the document feeder does not fall onto the exposure glass. When the document feeder is closed, points [A], [B], and [C] are aligned and no such force is provided to the document feeder.

The lift switch is actuated when the document feeder is closed. The copier then shifts to the document feeder mode. The lift switch also serves as the reset switch for document feeder misfeeds.

When a book or thick (maximum thickness 60 mm) original is copied, the DF acts as a cover for the original as shown in the figure [E]. The lift switch is turned off during this condition, so the DF does not function. The tension of spring [F] returns the DF to the normal condition after copying a thick original.

2.3 ORIGINAL MISFEED SENSING

The copier CPU lights the original misfeed indicator if the previous original remains on the exposure glass after manual copying and DF feed is attempted. When the DF is lifted and the previous original is removed, DF copying is permitted.

The registration sensor and the feed-out sensor are used for misfeed checks.

The functions of the two sensors are as follows:

1. One-sided original

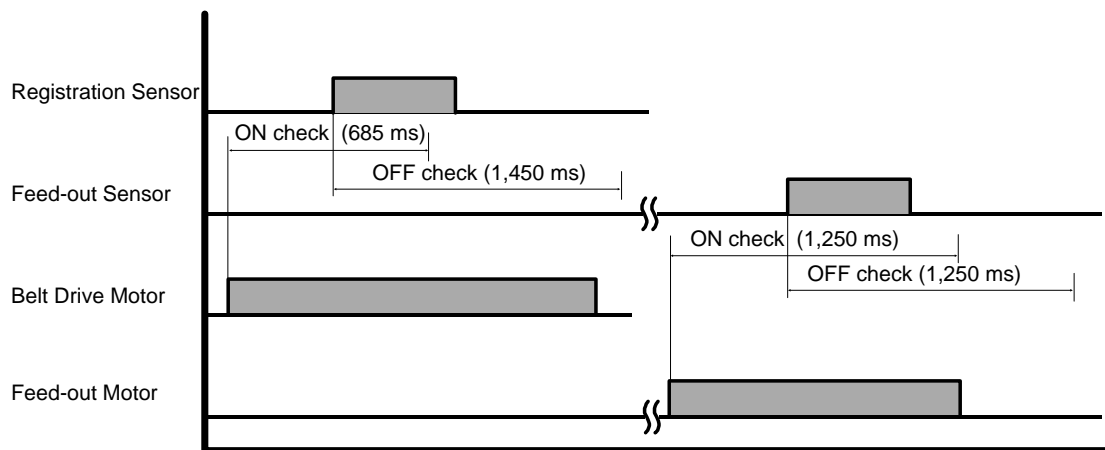

If the registration sensor is not actuated within 685 milliseconds after the belt drive motor starts turning, the Original Misfeed indicator lights (ON check). If the registration sensor does not turn off within 1,450 milliseconds, the CPU determines that there has been an original misfeed (OFF check). The Original Misfeed indicator also lights if the feed-out sensor is not actuated within 1,250 milliseconds after the belt drive motor starts turning forward (ON check), or if the feed-out sensor does not turn off within 1,250 milliseconds after the feed-out sensor turns on (OFF check).

2. Two-sided original

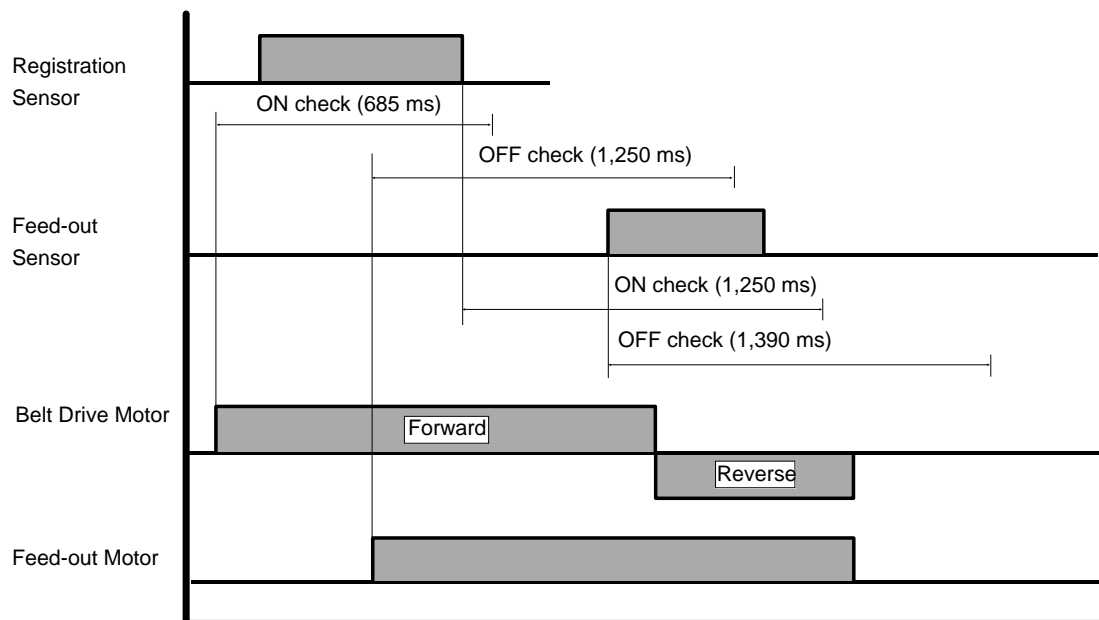

The Original Misfeed indicator lights if the registration sensor is not actuated within 685 milliseconds after the belt drive motor starts turning (ON check), or if the registration sensor does not turn off within 1,250 milliseconds after the feed-out motor starts turning (OFF check). If the registration sensor is not actuated within 1,250 milliseconds after the registration sensor turns off, the Original Misfeed indicator lights (ON check). The Original Misfeed indicator also lights if the feed-out sensor does not turn off within 1,390 milliseconds after the feed-out sensor turns on (OFF check).

The feed-out ON/OFF check is same as for one-sided originals.

1. DUMMY

2.

3. INSTALLATION

3.1 ACCESSORY CHECK

1. Installation Procedure (115 V version only).....	1 pc
2. NECR (115 V version only)	1 pc
3. Original Table	1 pc
4. Original Stopper.....	1 pc
5. DF Supporting Bracket	1 pc
6. Stopper Bracket.....	1 pc
7. Original Stopper Solenoid Assembly.....	1 pc
8. Front Scale Hinge.....	1 pc
9. Rear Scale Hinge	1 pc
10. Scale Holder	1 pc
11. Scale Sheet	1 pc
12. Installation Screws.....	15 pcs (total)
Pan Head Screw M5 x 10	2 pcs
Pan Head Screw M4 x 5	7 pcs
Pan Head Screw M4 x 6 (Gold: 2, Silver: 1)	3 pcs
Sunken Head Screw M3 x 5.....	1 pc
Philips Screw with Flat Washer M4 x 5.....	2 pcs
13. Toothed Washer	5 pcs
14. Document Set Decal.....	1 pc
15. Test Chart (A4)	1 pc
16. Lift Switch Actuator.....	1 pc
17. APS Actuator	1 pc
18. Envelope for NECR (115 V version only)	1 pc
19. DF Securing Retainer	1 pc

3.2 INSTALLATION PROCEDURE

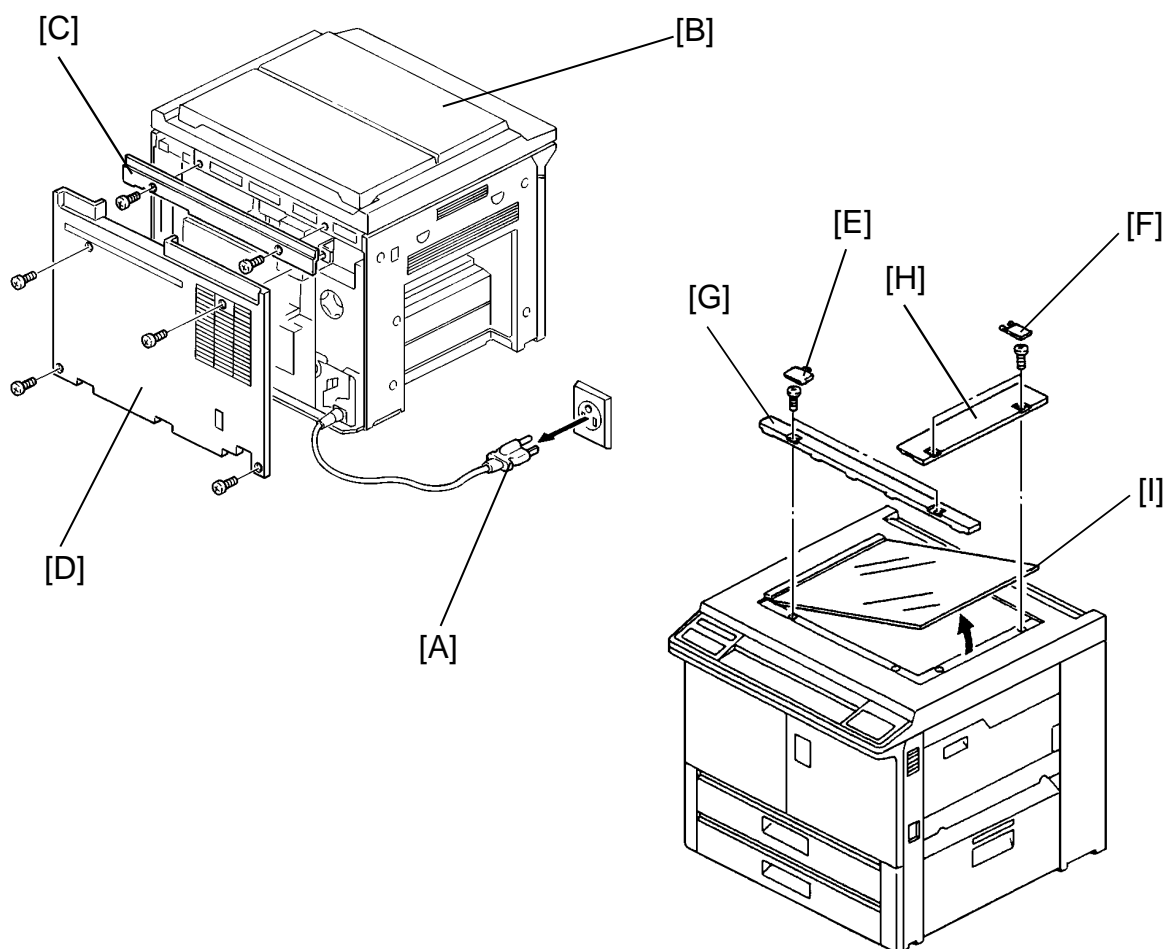

1. Unplug the power supply cord of the main system [A], then remove the platen cover if installed [B] (2 screws, 1 connector).
2. Remove the upper [C] and lower [D] rear covers (6 screws).
3. Remove the front [E] and right [F] scale screw covers.
4. Remove the front [G] and right [H] original scales (2 screws each).
5. Remove the exposure glass [I] as shown in the figure.

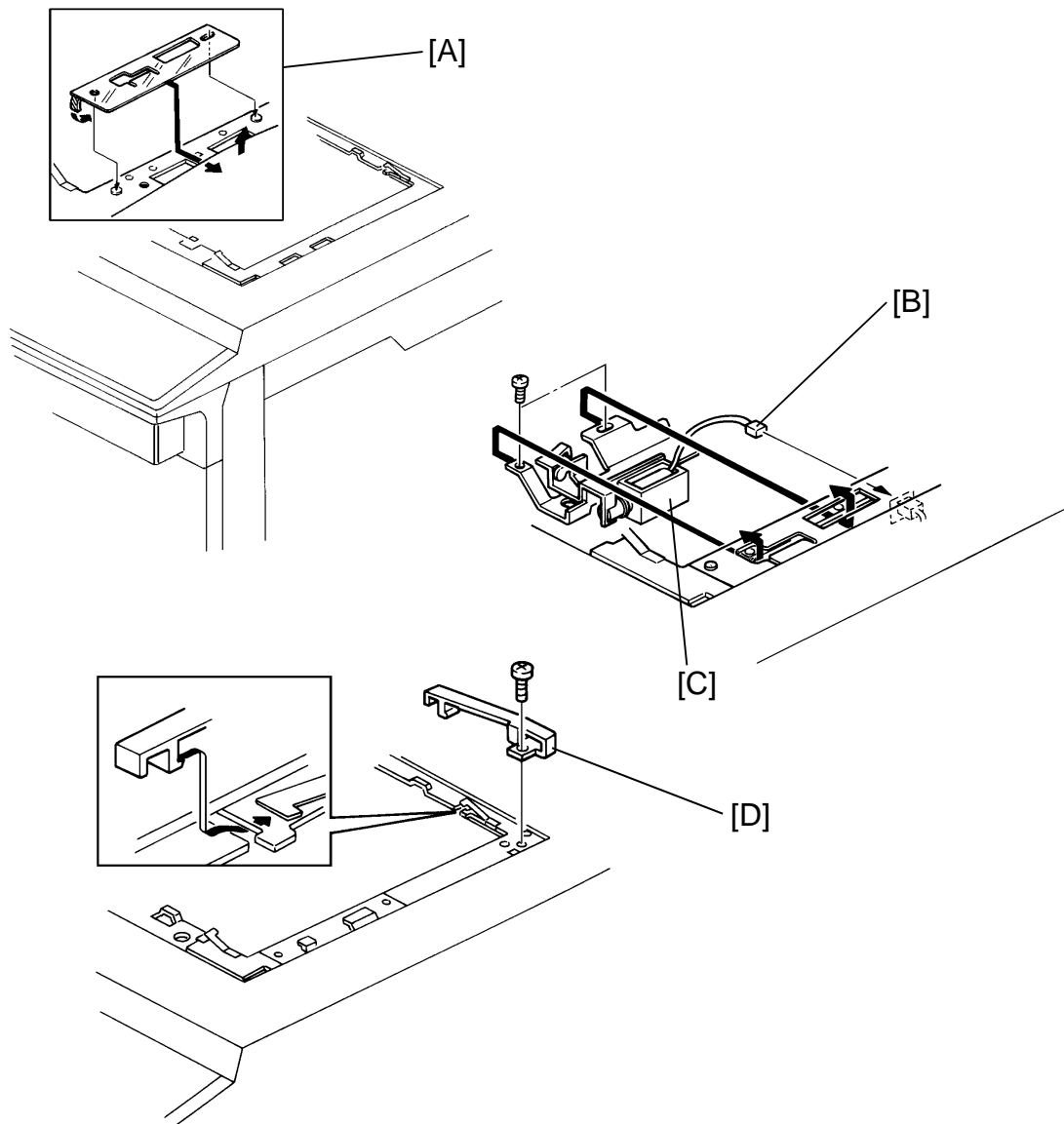

6. Peel off backing and stick the scale sheet [A] on the scale bracket as shown in the figure.
 7. Move the 1st scanner all the way to the left, and connect the original stopper solenoid connector [B] to the main machine.
 8. Install the original stopper solenoid [C] to the scale bracket as shown in the figure (2 M4 x 5 screws).
 9. Secure the rear scale hinge [D] as shown in the figure (1 M4 x 5 screw).
- NOTE:** Make sure the rear scale hinge leg is installed under the scale bracket.

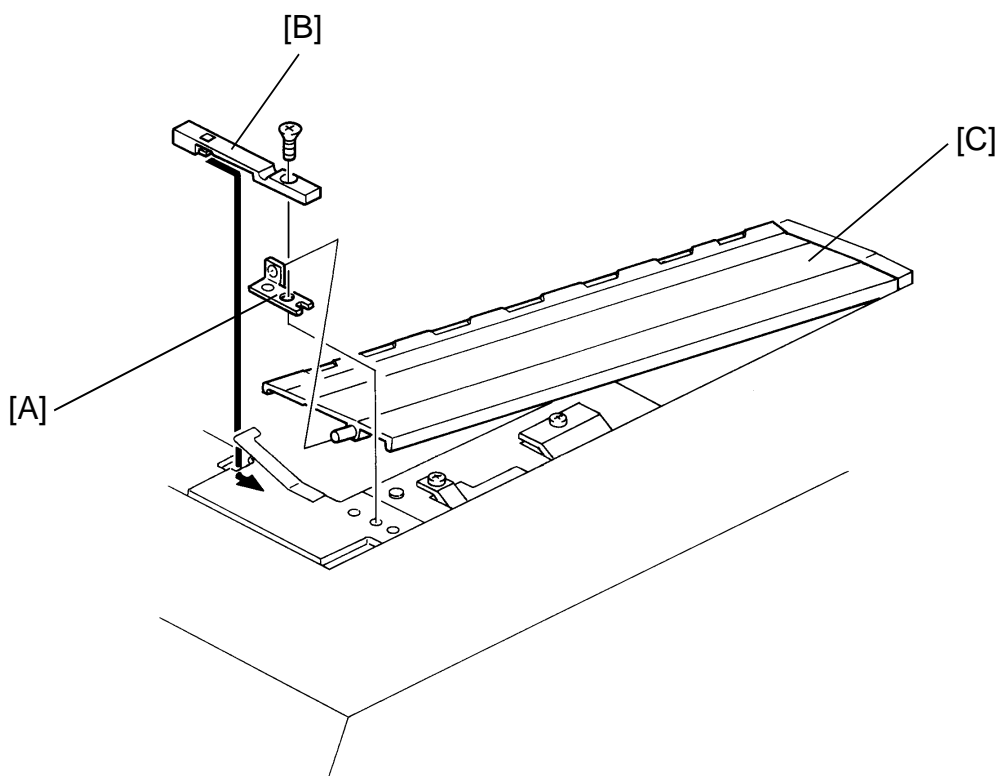

10. Attach the scale holder [A] under the front scale hinge [B], and set the original stopper [C] in place as shown in the figure.
11. Set the original stopper to the rear scale hinge, and secure the front scale hinge as in the figure (1 M3 x 5 sunken head screw).
NOTE: Make sure the front scale hinge leg is installed under the scale bracket.
12. Move the 1st scanner back to its home position.
13. Reinstall the exposure glass.

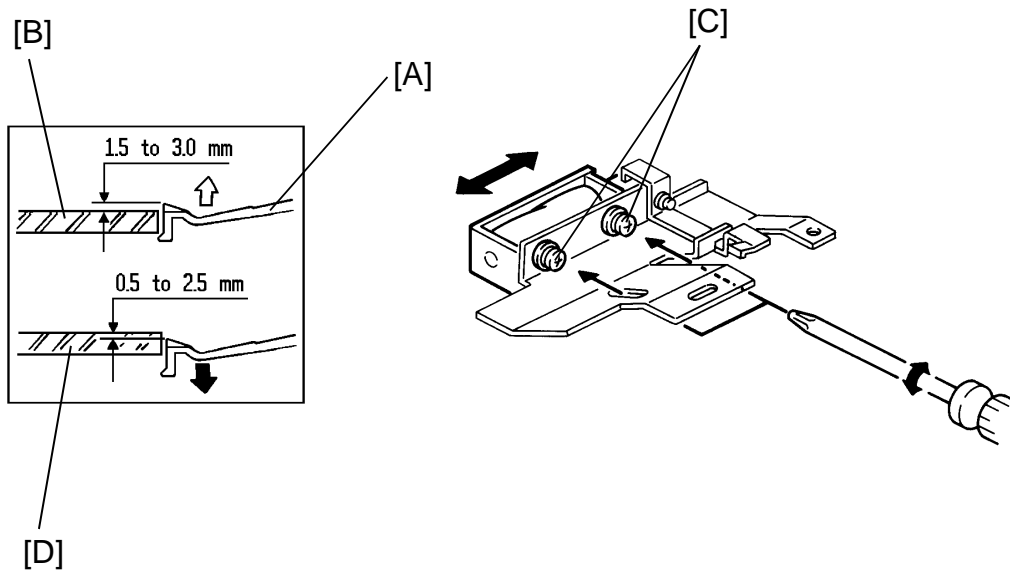

14. Check and adjust the original stopper.

Adjusting standard:

- a) The top of the original stopper [A] must be 1.5 to 3.0 mm higher than the exposure glass [B]. If not, adjust the solenoid stroke by moving the two screws [C].
- b) Press down the original stopper [A] and confirm that the top of the original stopper is 0.5 to 2.5 mm lower than the exposure glass [D].

15. Reinstall the following parts:

- a) Front original scale (2 M3 screws).
- b) Front screw covers.

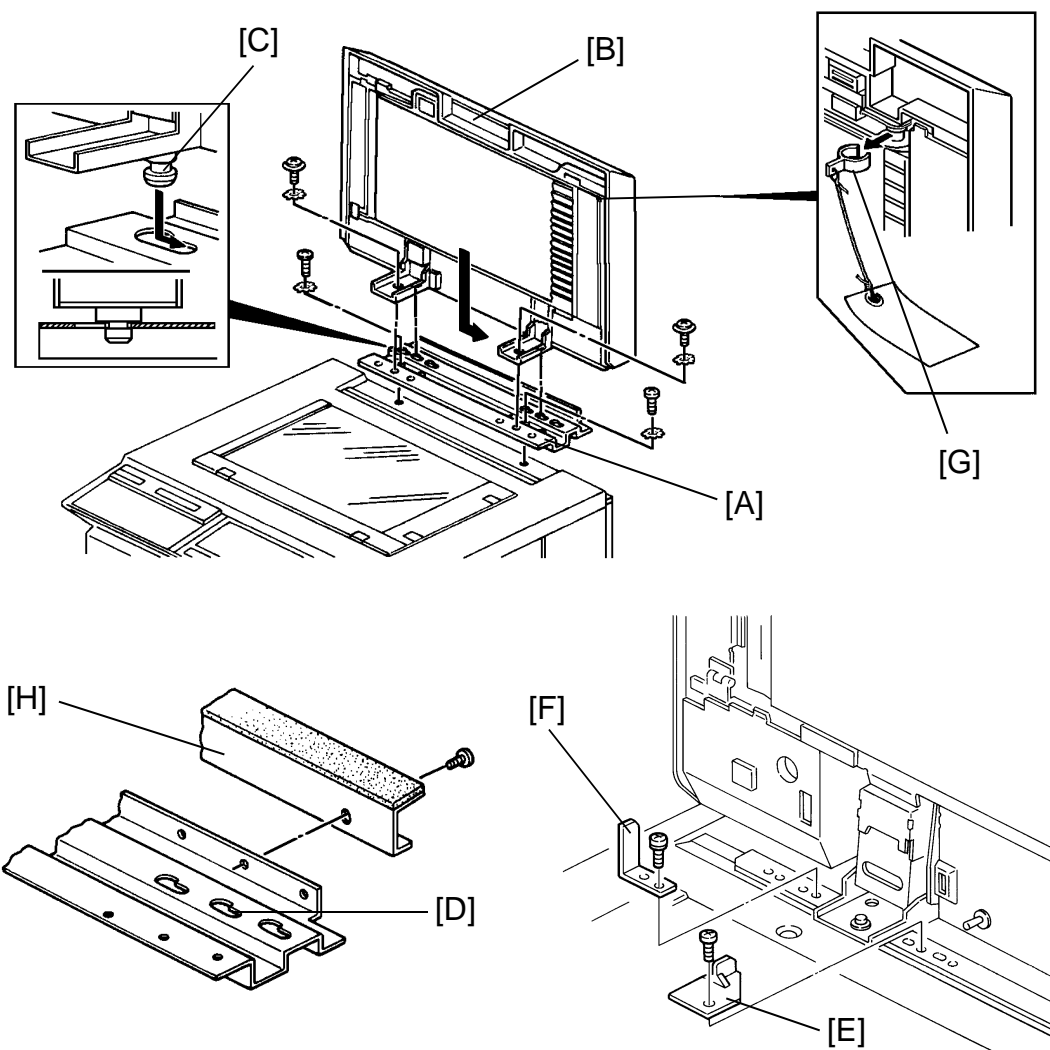

16. Remove the strip of tape and the plastic bag from the DF harness.
17. Install the DF supporting bracket [A] (2 M5 x 10 screws, 2 toothed washers).

NOTE: There are three holes on both sides of the DF supporting bracket. Use the center holes for standard installation.
18. Install the DF unit [B] on the DF supporting bracket (2 M4 x 5 screws with flat washer, 2 toothed washers).

NOTE: Insert the positioning pins [C] of the DF into the center holes [D] of the support bracket, then slide the DF to the right.
19. Install the lift switch actuator [E] and the APS actuator [F] (1 M4 x 5 screw each). Confirm that both actuators enter the slots when the DF is lowered.
20. Remove the shipping collar [G].
21. Lower the DF, and install the DF stopper bracket [H] (2 M4 x 5 screws).

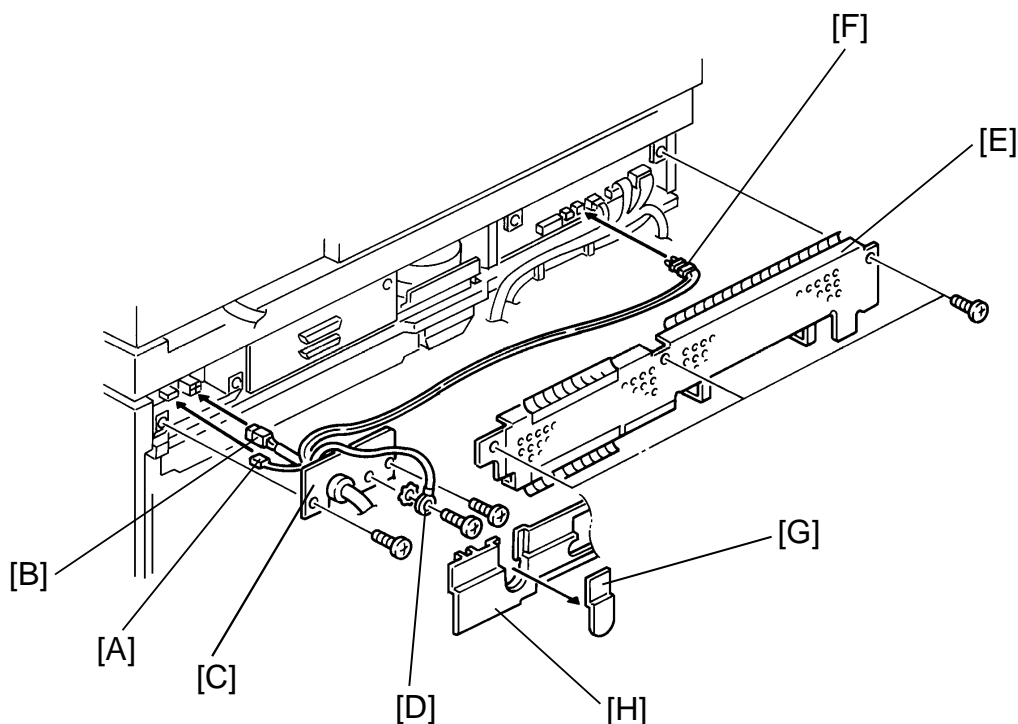

22. Connect the harness of the 3P [A] and 4P [B] connectors as shown in the figure.
 23. Mount the harness bracket [C] (2 M4 x 6 gold screws).
 24. Secure the DF ground wire [D] to the harness bracket as shown (1 M4 x 6 silver grounding screw and toothed washer).
 25. Remove the IPU board cover [E] (3 screws).
 26. Secure the fiber cable [F] to the 3 clamps, and connect it to the IPU board CN308.
 27. Remove the plastic cap [G] from the rear upper cover [H] to make a hole for the DF harness.
 28. Reinstall all the covers.
- NOTE:** Do not pinch the fiber optics cable when reinstalling the rear upper cover.

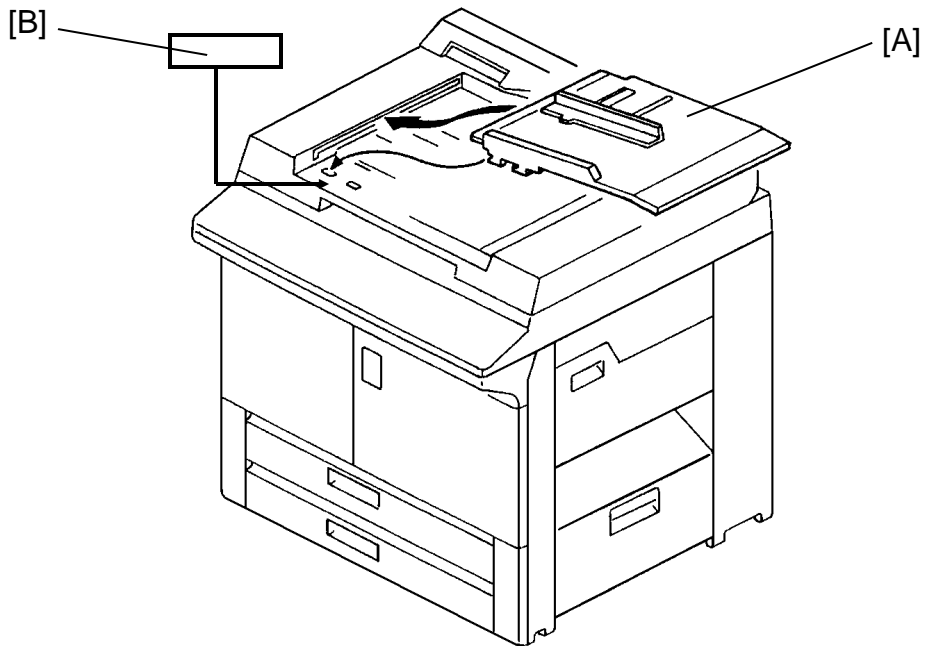

29. Insert the original table [A].
30. Stick the document set decal [B] to the DF.
31. Lift up the DF unit and select the thin mode on the original paper thickness select switch.
32. Plug in the power supply cord and turn on the copier main switch.
33. Check machine operation and copy quality.

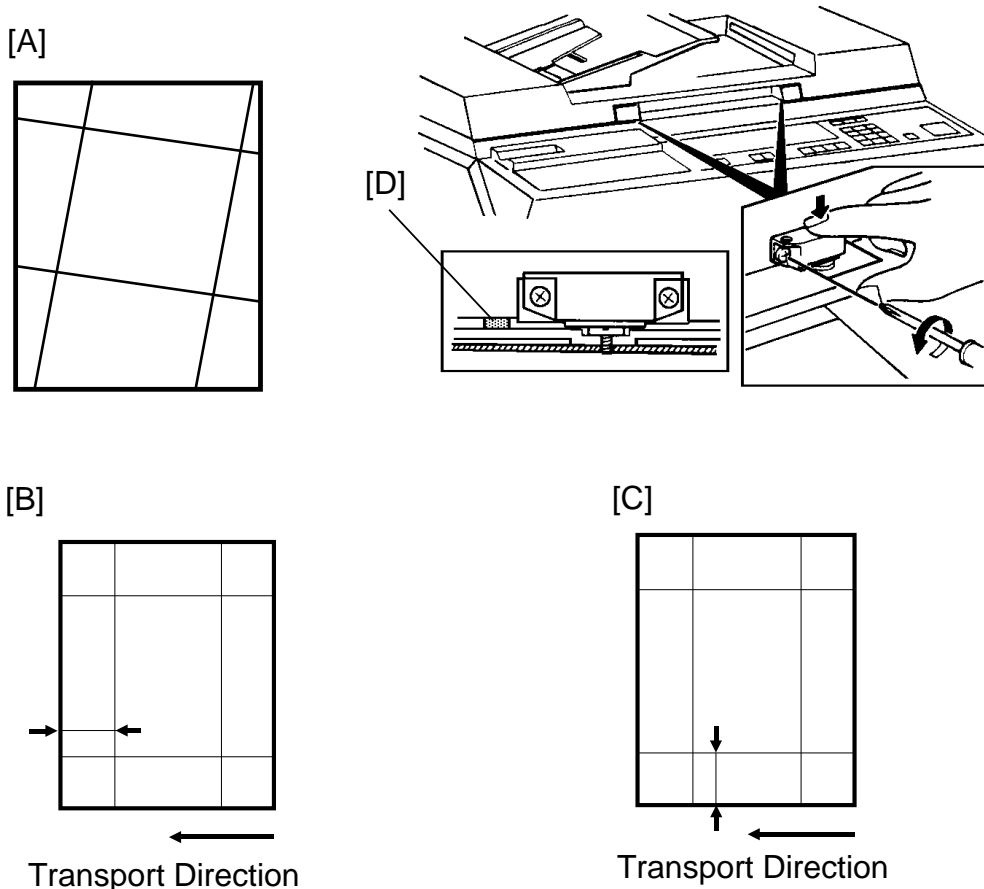

34. Check the original skew [A], the original leading edge registration [B] (both one-sided and double-sided copies), and the original side edge registration [C] according to the following steps:
35. DF height adjustment:
 - 1) Using the DF test chart, make a copy in the platen mode (8 $\frac{1}{2}$ " x 11"/A4 width).
 - 2) Confirm that the original select switch is in the thin mode and again using the test chart, make a copy in the DF mode (8 $\frac{1}{2}$ " x 11"/A4 width).
 - 3) Compare both copies and confirm that there is no skew between them.
 - 4) If there is skew, adjust the magnet catch positions so that the rubber pad [D] is in contact with the front original scale (2 screws each), after removing the DF grip (4 screws).

36. Original leading edge registration adjustment:

- 1) Using the DF test chart, make copies in both platen and DF (thin original) modes.
- 2) Compare the leading edge registration of both copies, and check that the difference between the two copies is within 2.5 mm.
- 3) If the difference is more than 2.5 mm, remove the DF main PCB cover (1 screw) and adjust VR102 on the DF main PCB until the leading edge registration is within specification.

NOTE: Turning VR102 clockwise results in stopping the original later (moving to the right).

- 4) Using the DF test chart, make a copy in the DF two sided-original mode. (Insert the original face down.)
- 5) Compare the leading edge registration with that of the platen cover mode copy, and check that the difference between the two copies is within 3.50 mm.
- 6) If out of specification, adjust VR103 on the DF main PCB until the leading edge registration is correct.

NOTE: Turning VR103 clockwise results in the original stopping later (moving to the left).

37. Original side edge registration:

- 1) Using the DF test chart, make copies in both platen and DF modes.
- 2) Compare the side edge registration of both copies, and confirm that the difference between the two copies is within 0 ± 2 mm (in two-sided mode 0 ± 3 mm).
- 3) If it is not, adjust the side edge registration using SP6-6.

NOTE: Using SP6-6, the side edge registration can be changed from -9 to $+9$ mm, in 0.5 mm steps. Setting the SP6-6 to the plus direction results in the copy image shifting to the left and vice versa.

38. Confirm the customer's requests, as the following functions can be selected if necessary:

- 1) Each Original Size Detection: SP6-2
- 2) Sort Priority: SP6-3 (when optional sorter installed)
- 3) Odd Number Duplex Copy: SP6-5
- 4) Thick Original Mode: Original Paper Thickness Switch

4. SERVICE TABLES

4.1 TEST POINTS

NUMBER	FUNCTION
TP101	Factory use
TP102	+5 V
TP103	GND
TP104	Factory use
TP105	+12 V
TP106	+24 V
TP107	Factory use

4.2 VARIABLE RESISTORS

NUMBER	FUNCTION
VR101	Belt drive motor speed adjustment.
VR102	Original leading edge registration adjustment (one-sided thin original mode).
VR103	Original leading edge registration adjustment (two-sided thin original mode).
VR106	Factory use (never adjust this VR).

4.3 LEDs

NUMBER	FUNCTION
LED101	Lights when the registration sensor is activated.
LED102	Goes out when the original width sensor is activated.
LED103	Goes out when the feed-out sensor is activated.
LED104	Lights when the pulse generator sensor is activated.
LED105	Lights when the original set sensor is activated.
LED106	Lights when the lift sensor is turned on.
LED107	Goes out when the original select switch is turned on (when the thin original mode is selected).

4.4 DIP SWITCHES

DPS 101				FUNCTION
-1	-2	-3	-4	
1	0	0	0	Normal mode
1	0	0	1	One-sided free run: SW101 - ON
0	1	0	1	Two-sided free run: SW101 - ON
0	0	1	1	Solenoid test: SW101 - solenoids ON SW102 - solenoids OFF
1	1	0	1	Motor test
1	1	1	1	All indicators ON

0: OFF 1: ON

- NOTE:**
- a) To use all functions, the DPS101 must be set to the normal mode when the main switch is turned on. At this time, the initial sequence between the copier and the DF will take place.
 - b) To use all functions except for the solenoid test mode, the lift switch must be turned on.
 - c) To use the one and two-sided free run modes, all sensors must be activated in the normal manner. Therefore, place the DF in the normal working position (down) and place paper on the original table. Then, turn on SW101 at the rear side of the DF.

5. REPLACEMENT AND ADJUSTMENT

5.1 FEED-IN UNIT

5.1.1 Transport Belt Replacement

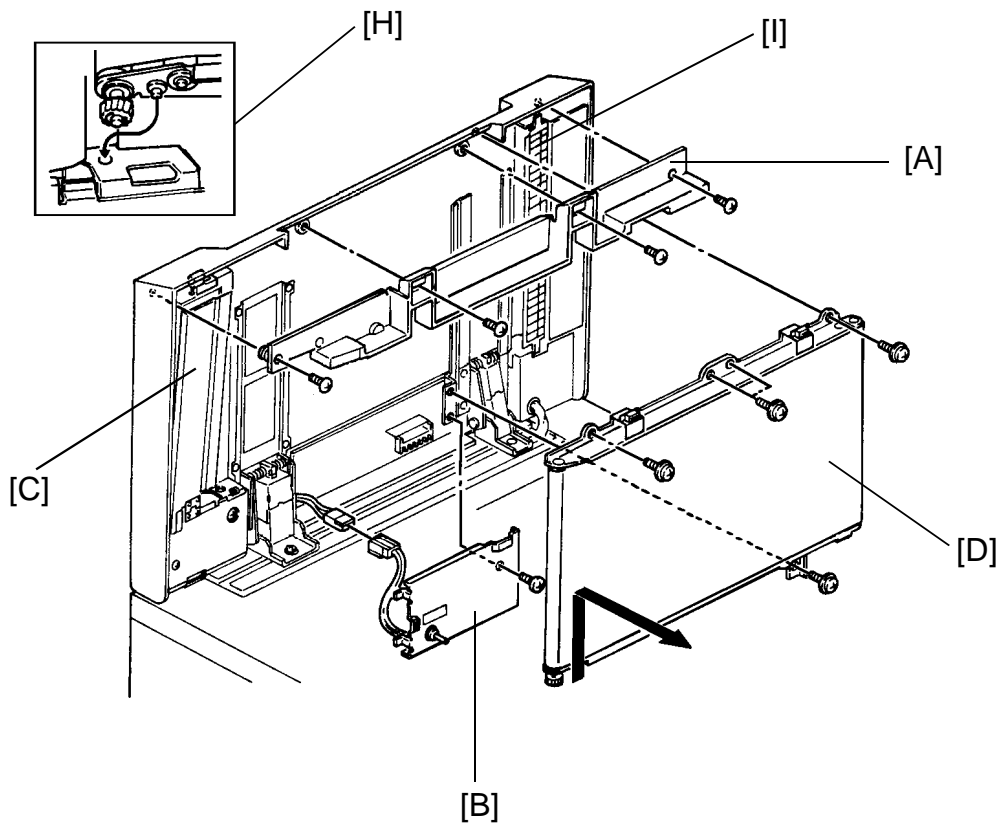

1. Turn off the main switch and remove the grip [A] (4 screws).
2. Remove the DF main PCB cover [B] (1 screw, 1 connector).
3. Open the entrance guide [C] and remove the transport belt assembly [D] (5 screws).

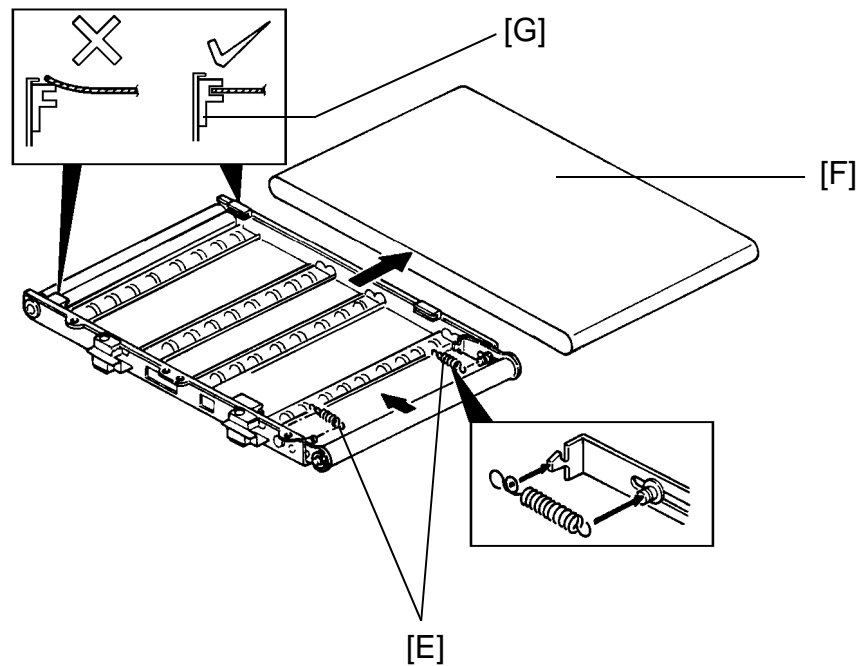

4. Remove the 2 tension springs [E] and pull off the transport belt [F].

- NOTE:** a) When installing the transport belt, make sure the belt lies between the belt guide spacers [G].
- b) When installing the transport belt assembly [D], make sure the positioning pin correctly fits in the DF frame [H], and hold open the exit guide [I] to prevent the mylar strip from becoming damaged.

5.1.2 Feed-in Unit Removal

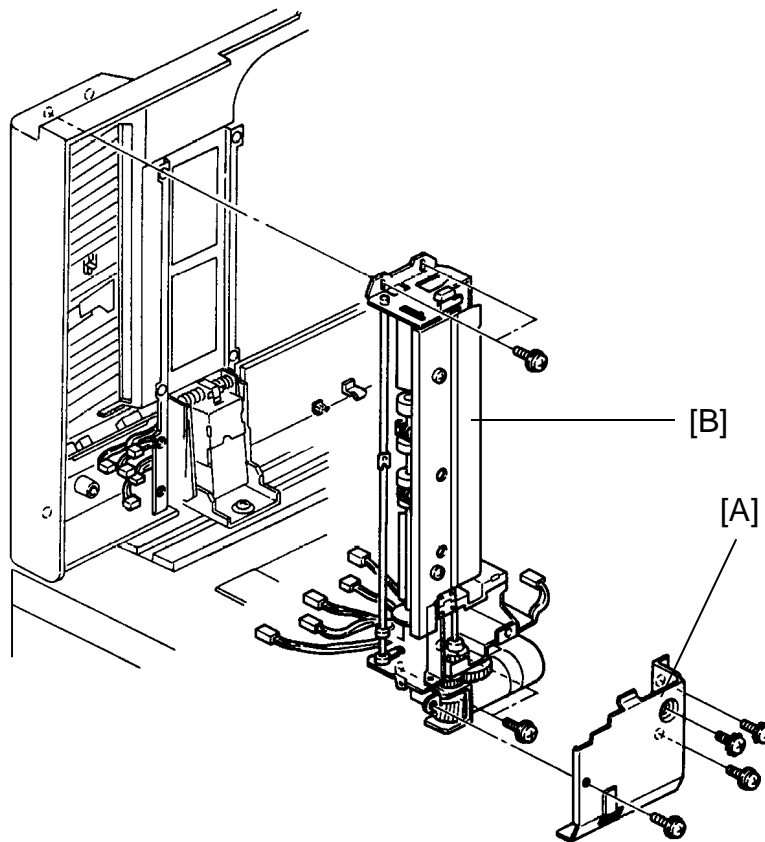

1. Turn off the main switch.
2. Remove the transport belt assembly. (See the Transport Belt Replacement section.)
3. Remove the belt drive motor cover [A] (4 screws).
4. Remove the feed-in unit [B] (4 screws, 7 connectors).

5.1.3 Pick-up Roller Replacement

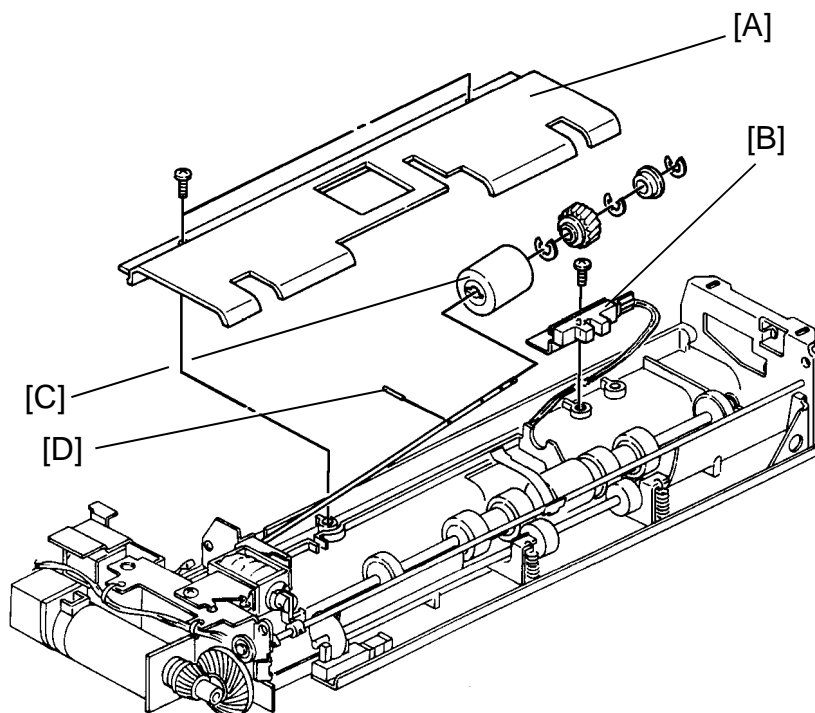

1. Turn off the main switch.
2. Remove the feed-in unit. (See the Feed-in Unit Removal section.)
3. Remove the lower entrance guide [A] (2 screws).
4. Remove the original set sensor assembly [B] (1 screw), without disconnecting the connector.
5. Remove the pick-up roller [C] (3 E-rings, 1 bushing, 1 gear).

- NOTE:**
- a) Be careful not to loosen the positioning pin [D].
 - b) When installing the roller, make sure the positioning pin is correctly inserted in the cut-out of the roller.
 - c) When installing the gear, make sure the flat side of the gear is facing away from the roller.

5.1.4 Feed-in Clutch Lubrication

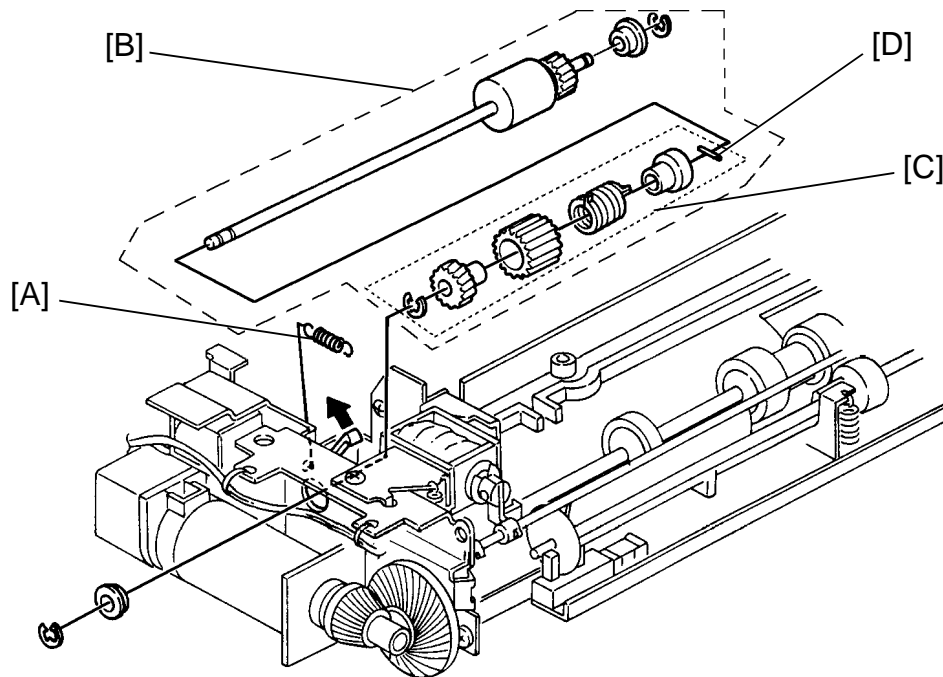

1. Turn off the main switch.
2. Remove the original set sensor assembly. (See the Pick-up Roller Replacement section.)
3. Remove the feed-in solenoid lever spring [A].
4. Remove the pick-up roller assembly [B] (2 E-rings, 2 bushings).
5. Disassemble and lubricate the feed clutch [C] (1 E-ring) with Mobil Temp. 78.

NOTE: a) Be careful not to loosen the positioning pin [D].
b) When installing the feed clutch, make sure the positioning pin is correctly inserted in the cut-out of the clutch.

5.1.5 Pick-up Solenoid Adjustment

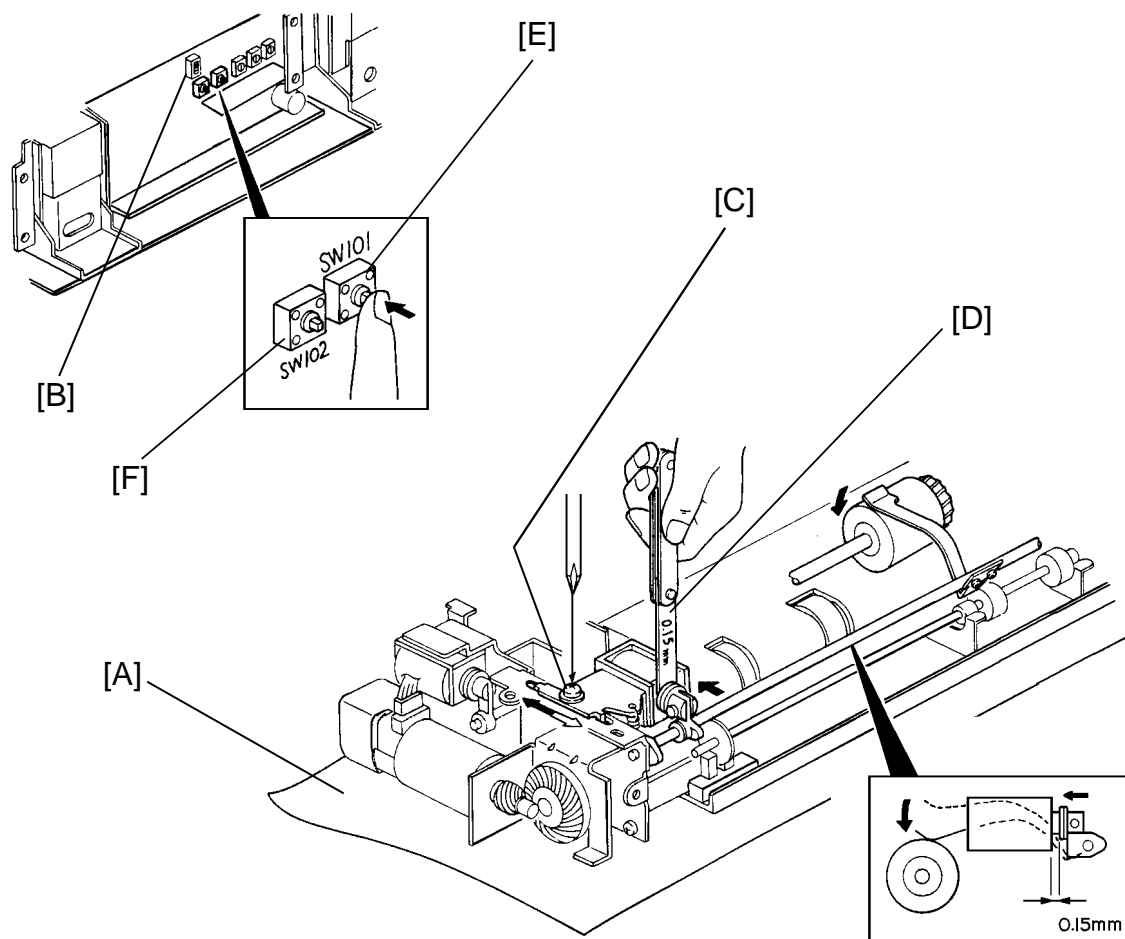

1. Turn off the main switch.
2. Place several sheets of paper [A] over the exposure glass area.
3. Lower the feed-in unit (see the Feed-in Unit Removal section) without disconnecting the seven connectors.
4. Turn on the main switch.

NOTE: When the main switch is turned on, the DPS101 [B] setting on the DF main PCB must be as follows:

1 = ON 3 = OFF
2 = OFF 4 = OFF

This is so that the initial check sequence can take place.

5. Turn off DPS101-1, then turn on DPS101-3 and 4 [B].
6. Loosen the screw fixing the pick-up solenoid [C].
7. Place the 0.15 mm thickness gauge [D] between the plunger and the solenoid.
NOTE: Two sheets of paper (20 lb/75 g/m²) can be used instead of a thickness gauge.
8. While holding the gauge, press SW101 [E] on the DF main PCB to engage all DF solenoids.
9. Keeping a 0.15 mm gap, move the solenoid slowly until the pick-up lever is just touching the pick-up roller.
10. Secure the screw fixing the pick-up solenoid [C].
11. Press SW 102 [F] to turn off the solenoids.
12. Set the DPS101 [B] for normal mode (1 = ON, 2 = OFF, 3 = OFF, 4 = OFF).
13. Turn off the main switch and reassemble the DF.
14. Check the original feed-in operation.

5.1.6 Feed Roller Replacement

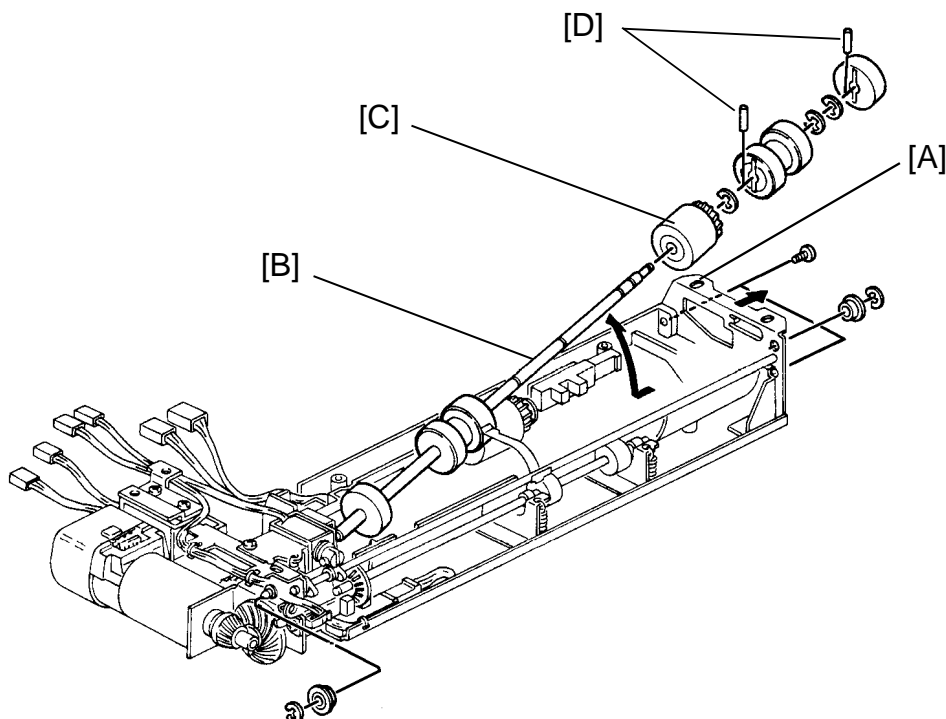

1. Turn off the main switch.
2. Remove the lower entrance guide. (See the Pick-up Roller Replacement section.)
3. Loosen the front bracket [A] (2 screws).
4. Release the feed roller shaft [B] from the front bracket (1 E-ring, 1 bearing).
5. Remove the feed roller [C] (3 E-rings, 1 side roller, 1 pull-out roller).

NOTE: a) Take care not to lose the positioning pins [D].

b) When installing the feed roller, make sure the gear side of the roller faces the front (see illustration).

c) When installing the side and pull-out rollers, make sure the positioning pins are correctly inserted in the cut-outs of the rollers.

5.1.7 Feed-in Solenoid Adjustment

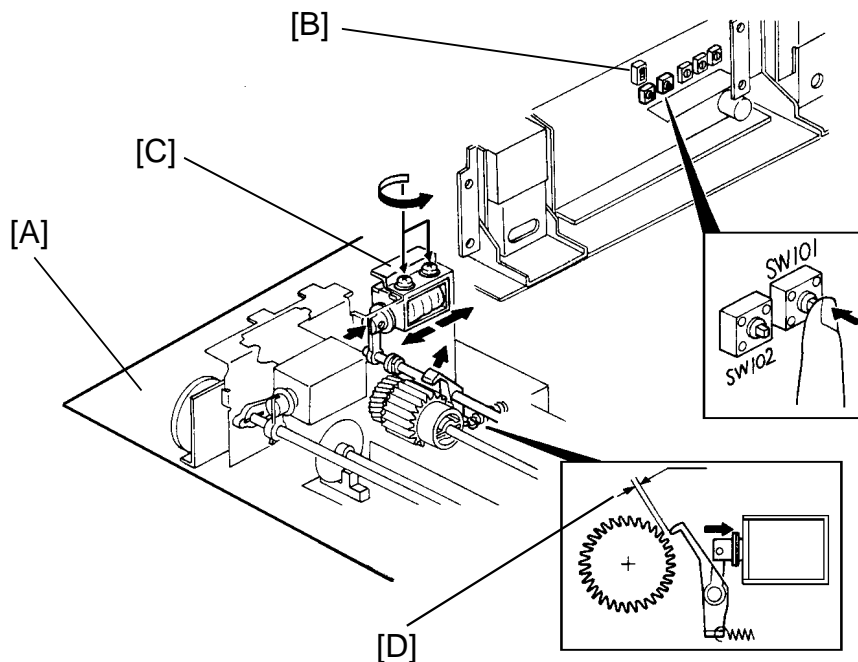

1. Turn off the main switch.
2. Place several sheets of paper [A] over the exposure glass area.
3. Lower the feed-in unit (see the Feed-in Unit Removal section) without disconnecting the seven connectors.
4. Check that DPS101 [B] is set for the normal mode (1 = ON, 2 = OFF, 3 = OFF, 4 = OFF).
5. Turn on the main switch.
6. Turn off DPS101-1, then turn on DPS101-3 and 4 [B].
7. Loosen the 2 screws securing the feed-in solenoid [C].
8. Press SW101 on the DF main PCB (to engage all DF solenoids) and adjust the position of the solenoid until the gap [D] (see illustration) is within 1.0 to 2.0 mm.
9. Press SW102 on the DF main PCB to turn off all DF solenoids.
10. Set the DPS101 [B] for normal mode (1 = ON, 2 = OFF, 3 = OFF, 4 = OFF).
11. Turn off the main switch and reassemble the DF.

5.1.8 Registration Sensor and Original Width Sensor Replacement

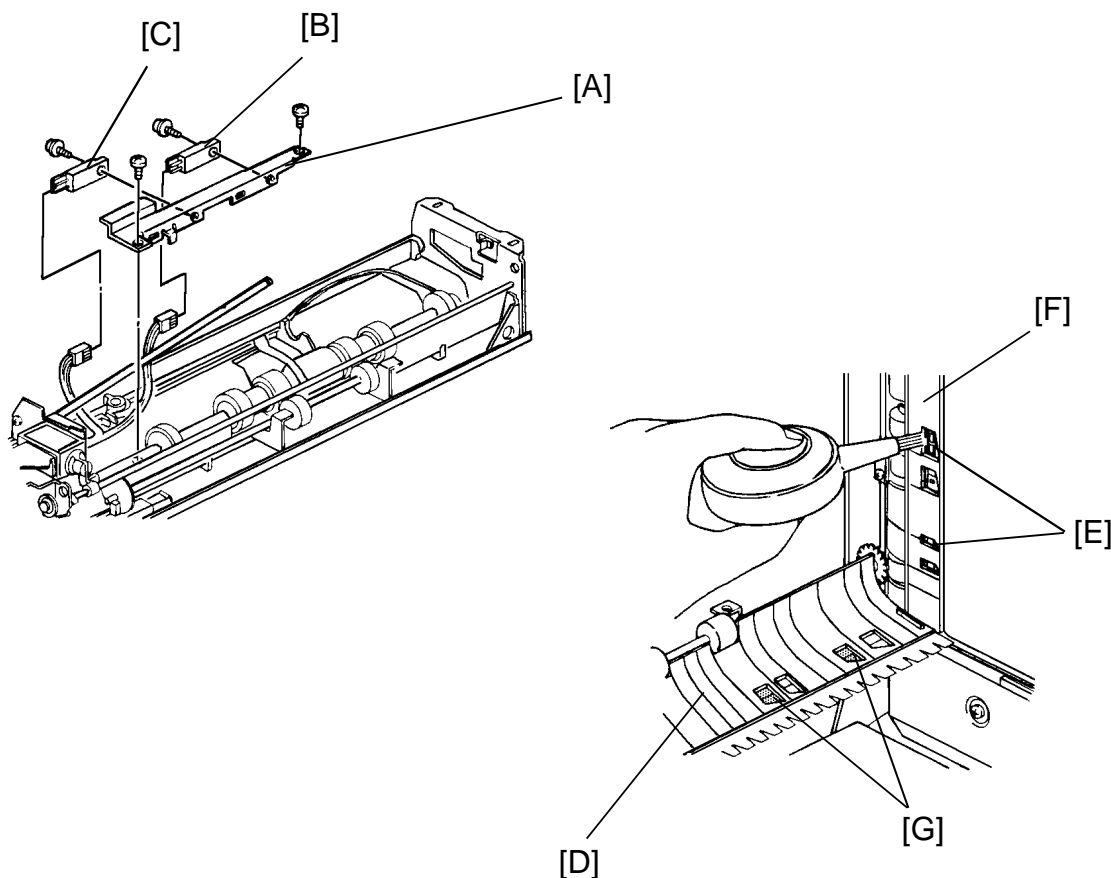

1. Turn off the main switch.
2. Remove the pick-up roller. (See the Pick-up Roller Replacement section.)
3. Remove the sensor holder plate [A] with the 2 sensors (2 screws).
4. Remove the registration sensor [B] and the original width sensor [C] (1 screw, 1 connector each).

NOTE: The registration sensor and the original sensor can be cleaned as follows:

Open the DF and release the lower guide plate [D] of the feed-in unit by pushing the lever for misfed paper removal. Then, clean the 2 sensors [E] from the cutout portion of the plastic guide plate [F]. Also, clean the black rubber seals [G] installed on the lower guide plate using a blower brush.

5.1.9 Friction Belt Replacement

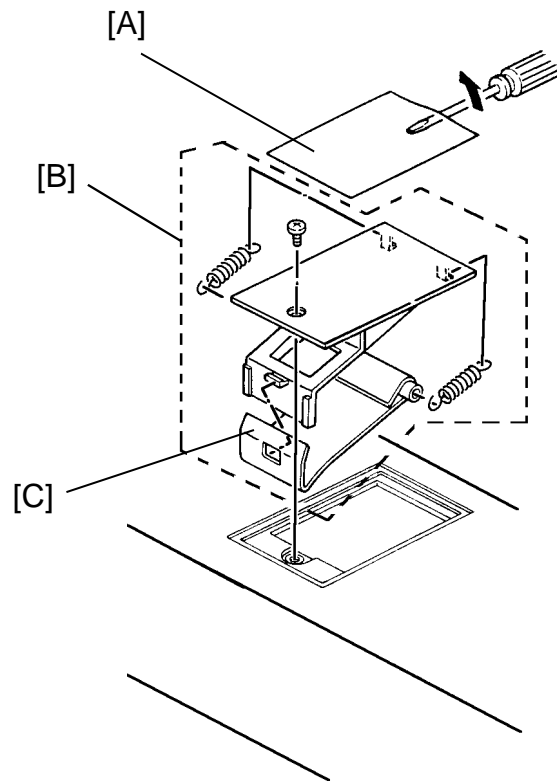

1. Turn off the main switch.
2. Remove the seal cover [A] on top of the DF cover.
3. Remove the friction belt assembly [B] (1 screw).
4. Remove the friction belt [C] (2 springs, 1 pin).

NOTE: If the seal cover becomes dirty or deformed, replace it with a new one.

5.1.10 Belt Drive Motor Speed Adjustment

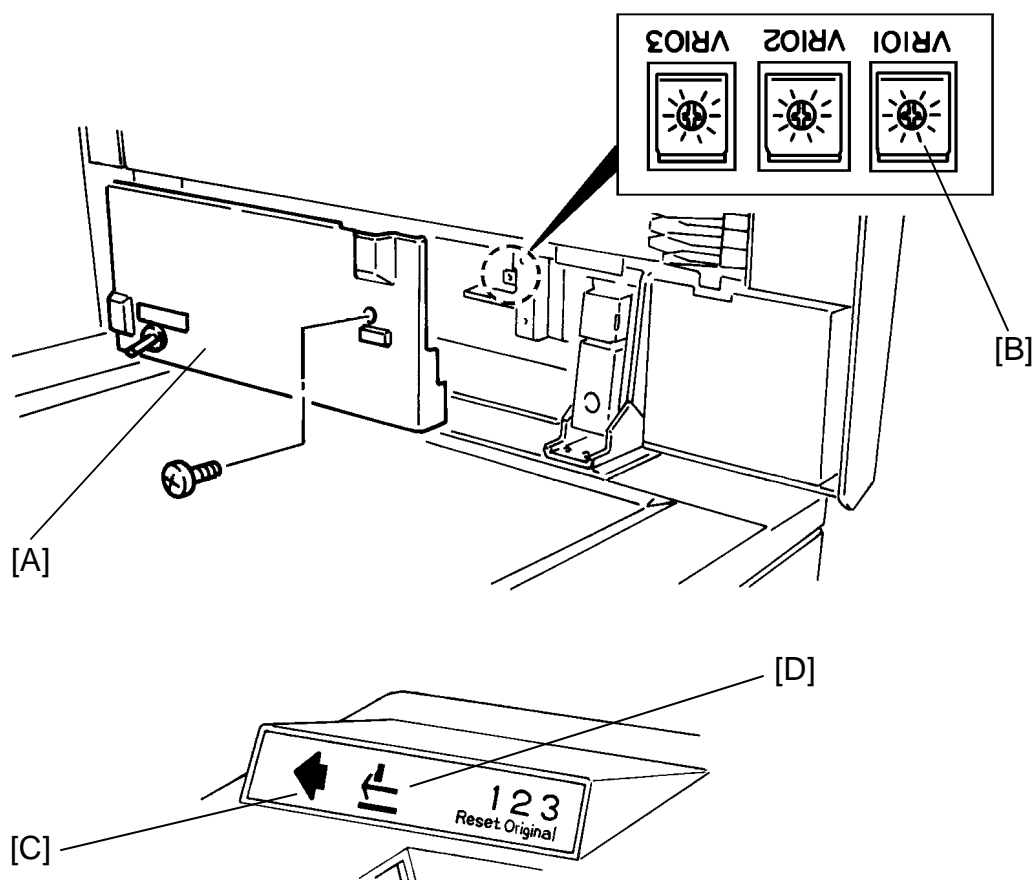

1. Remove the DF main PCB cover [A] (1 screw), without disconnecting the connector.
2. Turn on DPS 101-2 and -4.
3. While turning on the lift switch manually, adjust the belt drive motor speed to within 2,570 to 2,630 rpm using VR101 [B], so that both the Insert Original indicator [C] and the Auto Feed indicator [D] go out.

- NOTE:**
- a) When the Insert Original indicator lights , turn VR101 clockwise to reduce the motor speed.
 - b) When the Auto Feed indicator lights, turn VR101 counter clockwise to raise the motor speed.
 - c) Confirm that both indicators remain off for approximately 5 seconds, in order to steady the motor speed.
 - d) This procedure must be performed when replacing the DF main PCB.

4. Set DPS 101 for normal mode (1 = ON, 2 = OFF, 3 = OFF, 4 = OFF).

5.2 FEED-OUT UNIT

5.2.1 Feed-out Unit Removal

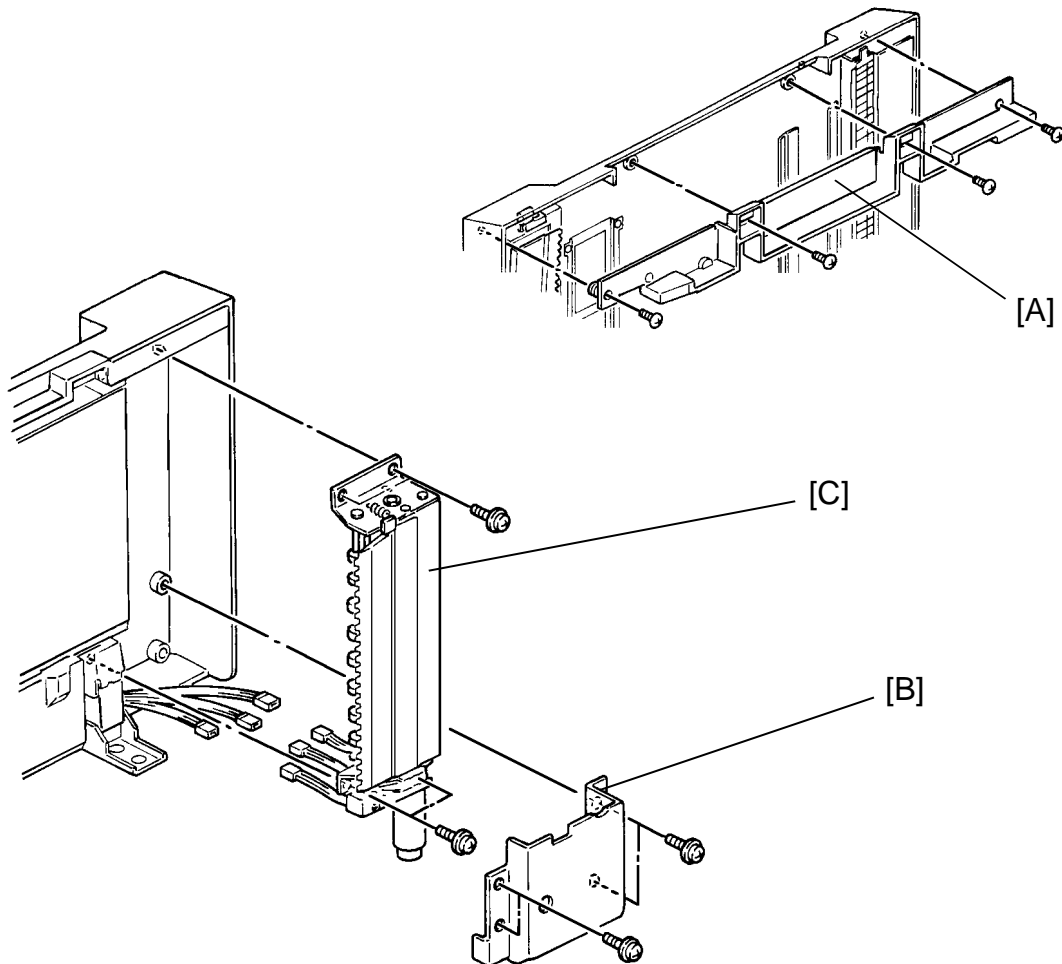

1. Turn off the main switch.
2. Remove the DF grip [A] (4 screws).
3. Remove the feed-out motor cover [B] (4 screws).
4. Remove the feed-out unit [C] (4 screws, 1 ground wire, 3 connectors).

5.2.2 Feed-out Sensor Replacement

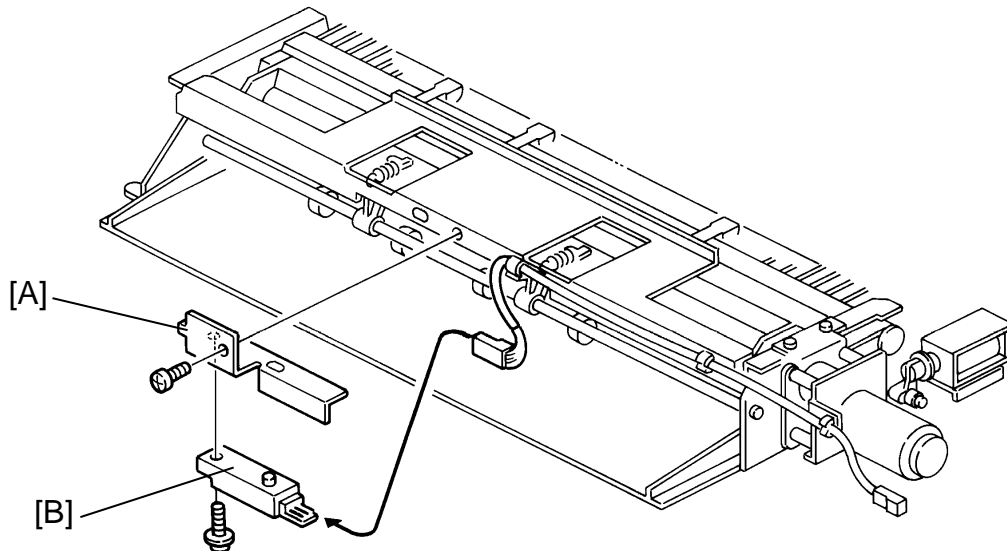

1. Remove the feed-out unit. (See the Feed-out Unit Removal section.)
2. Remove the sensor holder plate [A] with the sensor on (1 screw, 1 connector).
3. Remove the feed-out sensor [B] from the plate (1 screw).

5.2.3 Timing Belt Tension Adjustment

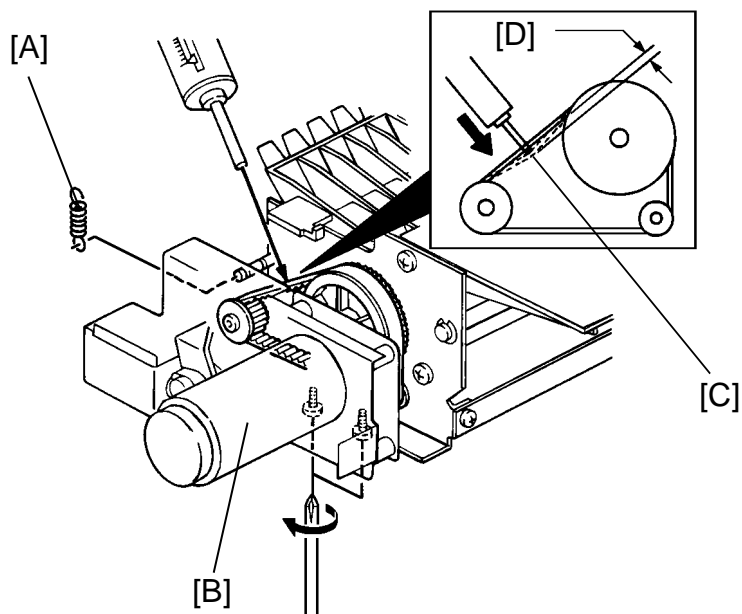

1. Turn off the main switch.
2. Remove the feed-out unit. (See the Feed-out Unit Removal section.)
3. Unhook the rear spring [A] of the feed-out unit entrance guide.
4. Loosen the 2 screws securing the feed-out motor assembly [B].
5. With a tension gauge, press the timing belt [C] in the center between the feed-out roller drive pulley and the inverter roller drive pulley.
6. Adjust the position of the feed-out motor assembly so that the slack of the timing belt becomes within 0.5 to 2.0 mm [D], when the tension gauge indicates 100 g.

5.2.4 Inverter Solenoid Adjustment

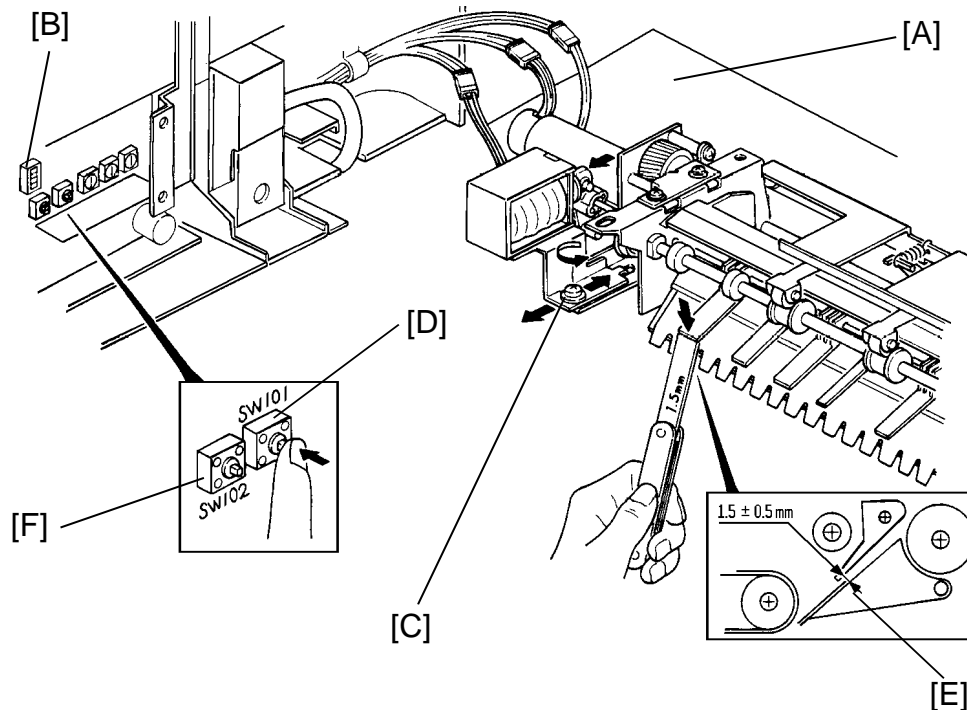

1. Turn off the main switch.
2. Place several sheets of paper [A] over the exposure glass area.
3. Lower the feed-out unit (see the Feed-out Unit Removal section) without disconnecting the three connectors.
4. Turn on the main switch.

NOTE: When the main switch is turned on, the DPS101 [B] setting on the DF main PCB must be as follows: 1 = ON, 2 = OFF, 3 = OFF, 4 = OFF.
5. Turn off DPS101-1, then turn on DPS101-3 and 4 [B].
6. Loosen the screw securing the inverter solenoid [C].
7. Press SW101 [D] on the DF main PCB (to engage all DF solenoids), and adjust the position of the solenoid until the gap [E] (see illustration) is within 1.0 to 2.0 mm.
8. Press SW102 [F] on the DF main PCB to turn off all DF solenoids.
9. Set the DPS101 [B] for normal mode (1 = ON, 2 = OFF, 3 = OFF, 4 = OFF).
10. Turn off the main switch and reassemble the DF.

5.2.5 Feed-out Motor Unit and Inverter Roller Replacement

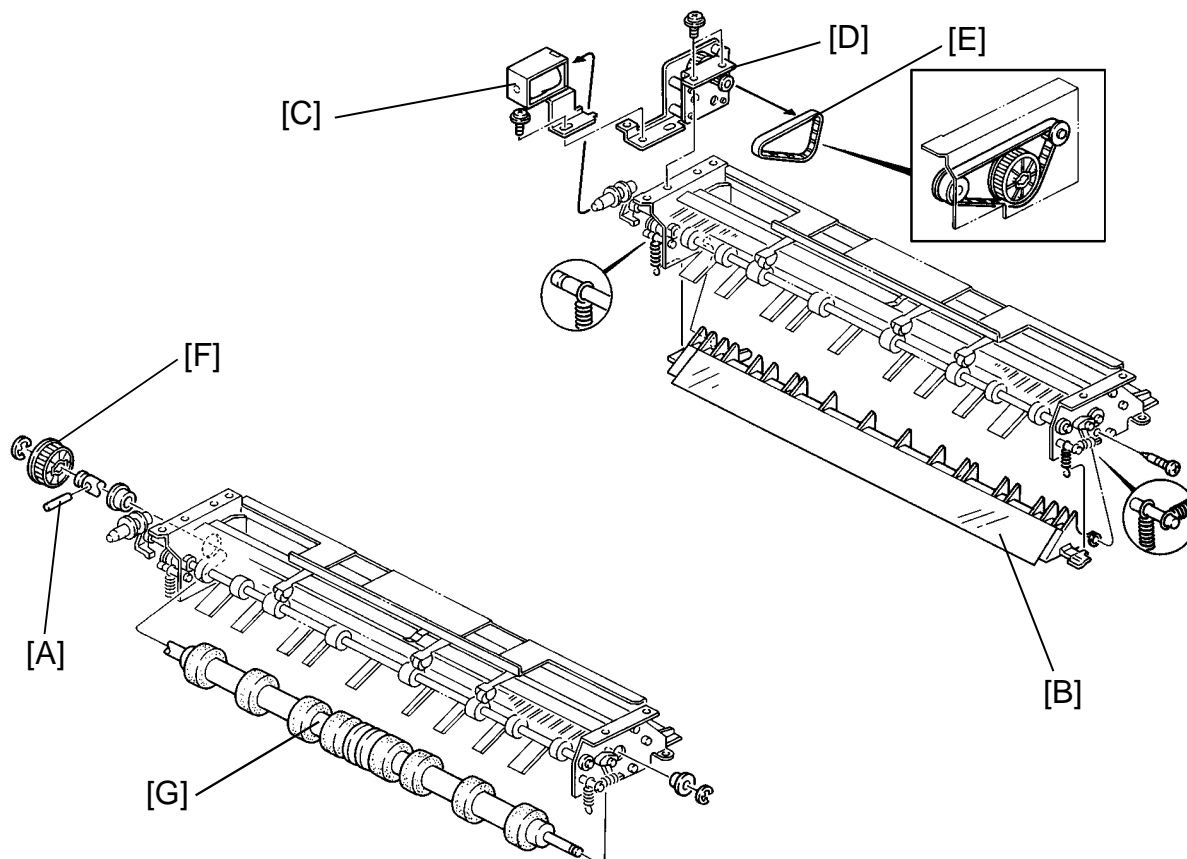

CAUTION: Be careful not to mix up the springs when removing the inverter guide plate. Be careful not to lose the positioning pin [A].

1. Remove the feed out unit. (See the Feed-out Unit Removal section.)
2. Remove the inverter guide plate [B] (1 screw, 2 springs).
3. Remove the inverter solenoid with the bracket on [C] (1 screw).
4. Remove the feed-out motor unit [D] (2 screws), and the timing belt [E].
5. Remove the inverter roller pulley [F] (1 E-ring).
6. Remove the inverter roller [G] (1 E-ring, 2 bushing).

NOTE: After reinstalling the feed-out motor unit, perform the following adjustment procedures.

- a) Timing belt tension adjustment.
- b) Inverter solenoid adjustment.

5.2.6 DF Leading Edge Registration Adjustment

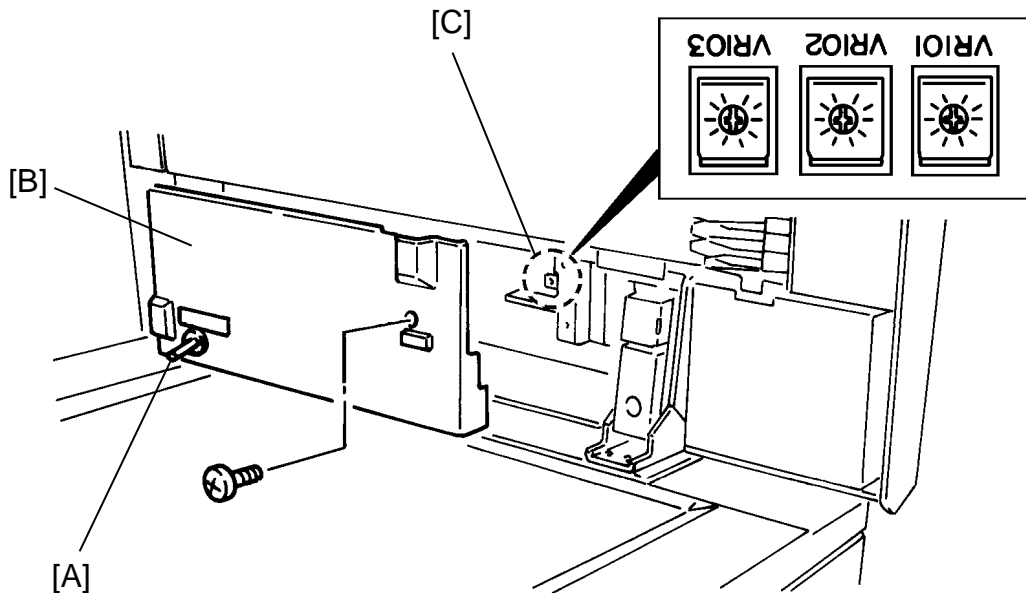

1. Using the DF test chart, make a copy in the platen cover mode (A4 width).
2. Confirm that the original select switch [A] is in the thin mode and again using the test chart, make a copy in the DF mode (A4 width).
3. Compare the leading edge registration of both copies, and check that the difference between the two copies is within 2.5 mm.

4. If the difference is more than 2.5 mm, remove the DF main PCB cover [B] (1 screw, 1 connector) and adjust VR102 on the DF main PCB [C] until the leading edge registration is within specification.

NOTE: Turning VR102 clockwise results in stopping the original later (moving to the right).

5. Using the DF test chart, make a copy in the DF two sided-original mode. (Insert the original face down.)

6. Compare the leading edge registration with that of the platen cover mode copy, and check that the difference between the two copies is within 3.5 mm.

7. If out of specification, adjust VR103 on the DF main PCB until the leading edge registration is correct.

NOTE: Turning VR103 clockwise results in the original stopping later (moving to the left).

NOTE: This procedure must be performed when replacing the DF main PCB.

5.2.7 DF Side Edge Registration Adjustment

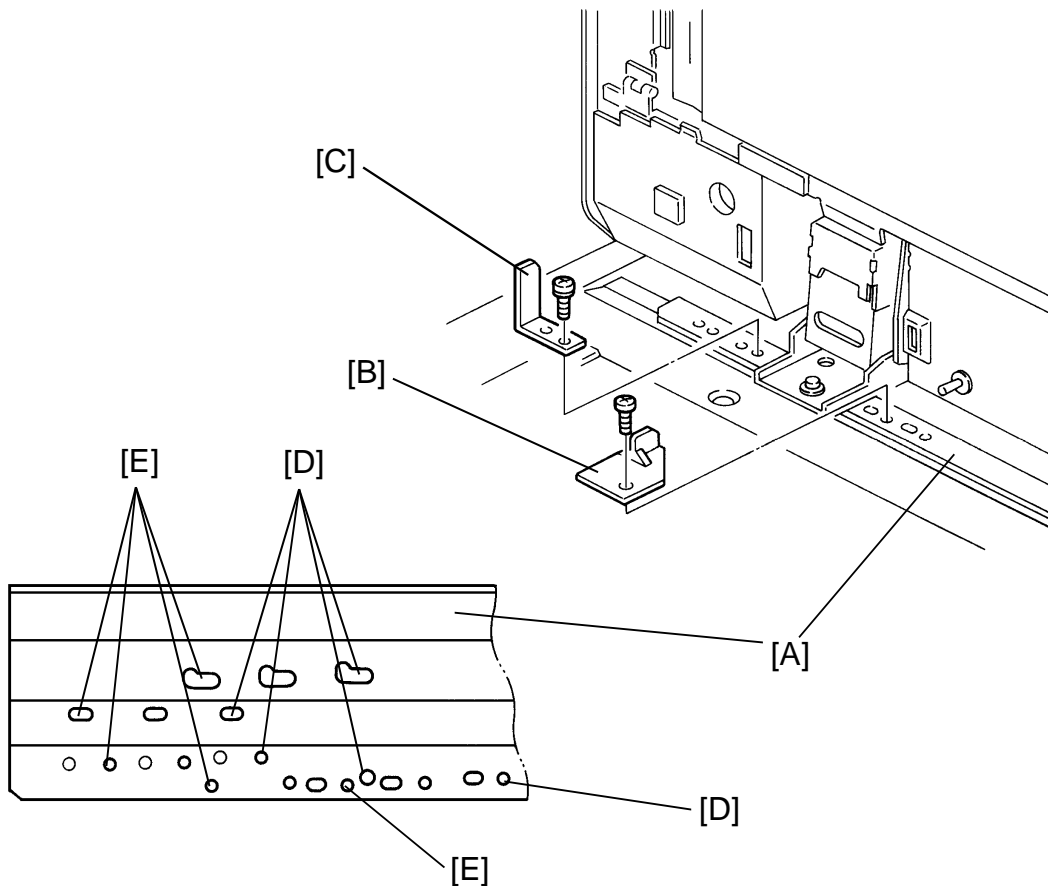

1. First check the position of the original path by setting the DF test chart on the original table.
2. Press the Start key, then press the Clear/Stop key shortly after the DF test chart is fed.
3. Open the DF carefully, and check the distance between the front side edge of the DF test chart and the front original scale. If it is 2.0 mm or more, go to step 5.
4. If the distance is less than 2.0 mm, move the DF supporting bracket [A] to the left, and then install the DF, the lift switch actuator [B], and the APS actuator [C] using holes [D].

NOTE: a) If the distance is less, the original might hit the front original scale, resulting in original misfeeds or skewing.
 b) Moving the DF supporting bracket one set of holes at a time gives a 1.5 mm difference horizontally relative to the position of the original path.

5. To adjust the side edge registration, make a copy in platen mode using the DF test chart.
6. Again using the test chart, make a copy in DF mode.
7. Compare the side edge registration of both copies, and confirm that the difference between the two copies is within 2.0 mm (in two-sided original mode, within 3.0 mm).
8. If it is out of specification, adjust the side edge registration using SP Mode No. 6-6. (For SP Mode access, see the SP Mode list.)
NOTE Using SP Mode No. 6-6, the side edge registration can be changed from -9 to +9 mm, in 0.5 mm steps. Setting the SP Mode No. 6-6 to the plus direction results in the copy image shifting to the left of the copy and vice versa.
9. If the difference is more than 9 mm, move the DF supporting bracket [A] to the right, then install the DF, the lift switch actuator [B], and the APS actuator [C] using the holes [E]. Then, repeat steps 7 and 8.